



ADVANCED HEAT EXCHANGERS

BRAZED PLATE HEAT EXCHANGERS

ONDA is a leading company in Heat Exchange, partner of all main Chiller manufacturers. ONDA produces a complete range of Brazed Plate Heat Exchangers dedicated to Refrigeration and Air Conditioning. Our evaporators and condensers are available with different raw materials and well adapted to different refrigerants (R22, R134a, R410A...) from 3 to 200 Tons. All our products are manufactured under ISO 9001 with all the main worldwide certifications: PED, UL.

TECHNICAL INFORMATION

The main applications of our brazed plate heat exchangers are the evaporation and the condensation of the refrigerant gas in the air conditioning and refrigeration plants, the hot water production in heat pumps, the heat recovery.

Suitable refrigerants are all HCFCs, HFCs and others, unless they are compatible with the manufacturing materials.

The dimensional data contained in this catalogue are to be intended indicative taking into account the manufacturing tolerances. We reserve the right to apply changes to this catalogue without prior notice.

The design of the plate corrugation pattern has been optimized thanks to a CFD analysis supported by thermal laboratory test.

MATERIALS

The top quality materials used to manufacture the ONDA brazed plate heat exchangers satisfy the requirements of the 2014/68/EU Directive (Pressure Equipment Directive). The type construction of the brazed plate heat exchangers consists of:

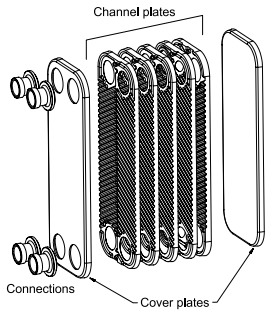

- Material of the BPHE :**
- Channel plates: Stainless steel AISI 316L
 - Cover plates: Stainless steel AISI 304L
 - Connections: Stainless steel AISI 304L
 - Brazing material: Copper

ACCESSORIES

Following optionals are available on request:

- Stud bolts (front / rear / front-rear)
- Mounting feet / brackets
- Insulation.

ONDA Brazed plate heat exchangers carry the UL Mark for US and Canada (ref. no.SA32759)



Configuration- connections SINGLE CIRCUIT							
FOUR connections							
F1	F2	W1	W2				Code
F1	F2			BW1	BW2		AA
F1	F2	W1			BW2		AB
F1	F2		W2	BW1			AC
	F2	W1		BW1			AD
	F2					BF2	AE
	F2	W1			BW2	BF1	AF
F1			W2		BW2	BF1	AG
F1			W2	BW1		BF2	AH

FIVE connections							
F1	F2	W1	W2	BW1			BA
F1	F2	W1	W2			BW2	BB
F1	F2	W1		BW1		BW2	BC
F1	F2		W2	BW1		BW2	BD

SIX connections							
F1	F2	W1	W2	BW1	BW2		CA
F1	F2	W1	W2			BF1	CB
F1	F2	W1	W2	BW1			CC
F1	F2	W1	W2		BW2	BF1	CD

EIGHT connections							
F1	F2	W1	W2	BW1	BW2	BF1	BF2
							DA

Configuration- connections DUAL CIRCUIT							
SIX connections							
F1	F2	G1	G2			BW1	BW2
F1	F2	G1	G2	W1	W2		
F1	F2	G1	G2	W1		BW1	BW2
F1	F2	G1	G2		W2	BW1	BW2
F1	F2	G1	G2	W1	W2	BW1	
F1	F2	G1	G2	W1	W2		BW2
EIGHT connections							
F1	F2	G1	G2	W1	W2	BW1	BW2
							PA

SEE PAGE 39-40 FOR THE DRAWINGS CONFIGURATIONS



pathlines-1
Velocity Magnitude

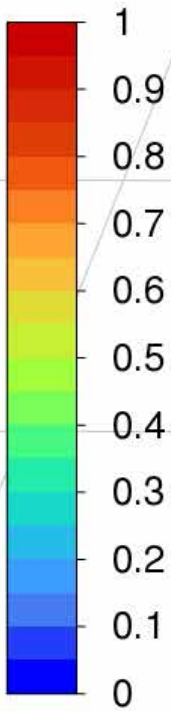

[m/s]

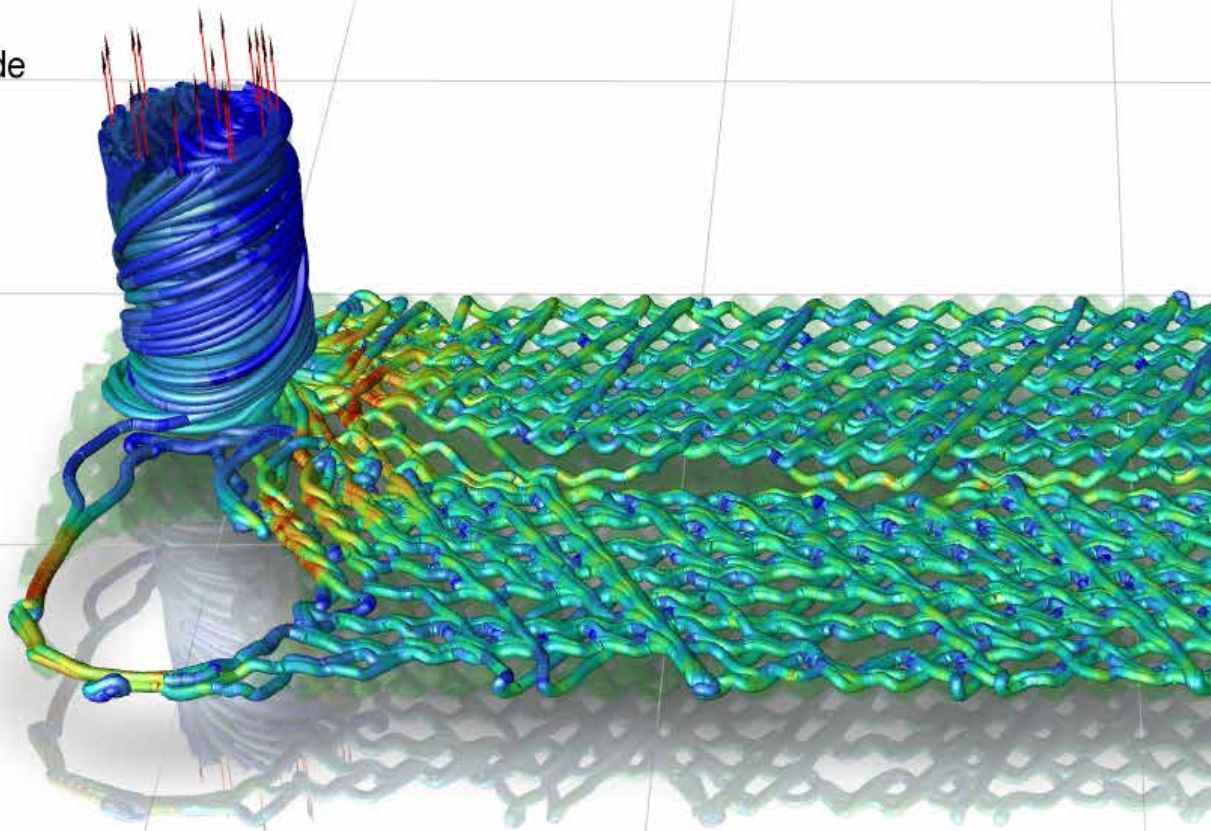

SINGLE CIRCUIT	p. 7
DUAL CIRCUIT	p. 27
LIQUID SUCTION GAS	p. 31
CONNECTIONS	p. 36
INSULATION	p. 43
TABLES PRESSURE/ TEMPERATURE	p. 44

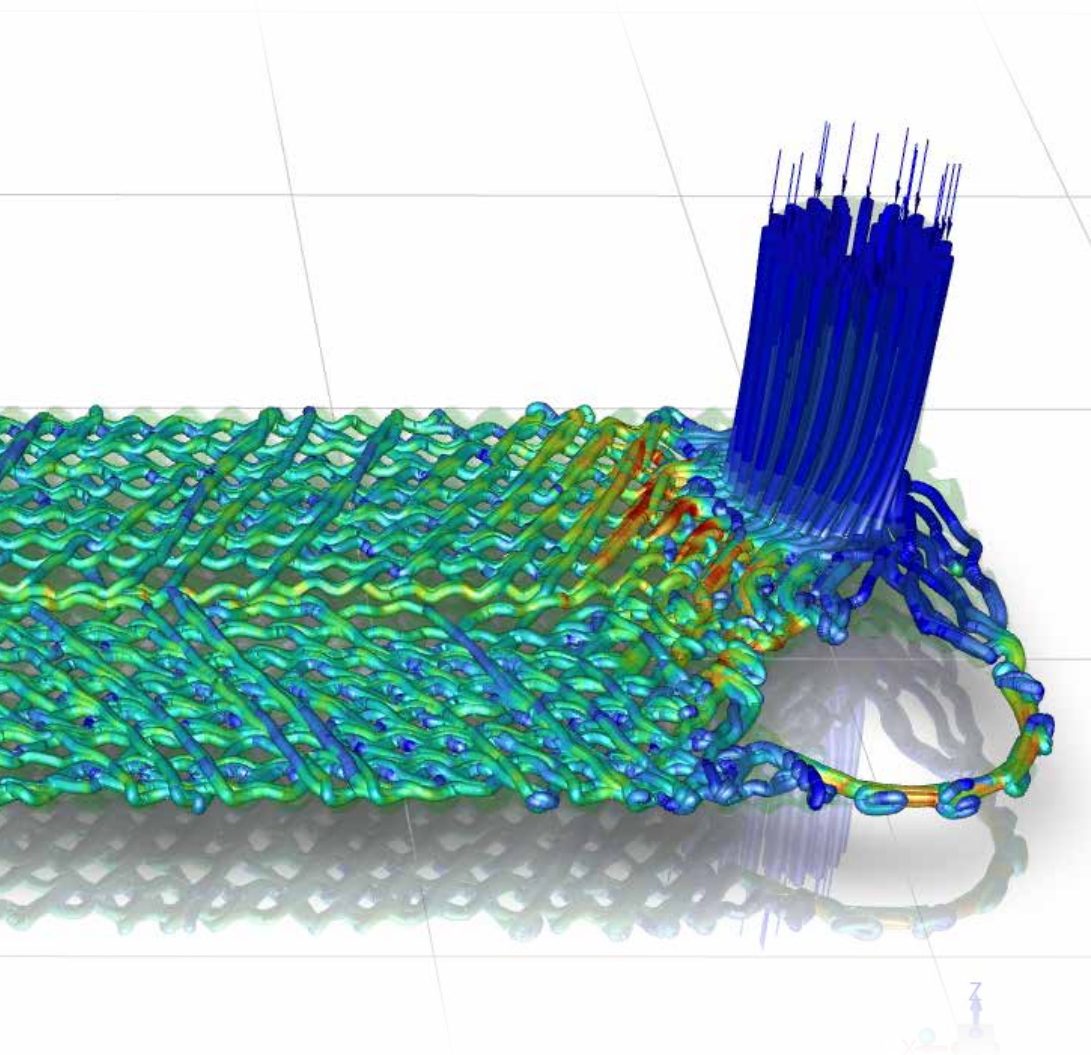

Number of plate

Operating conditions **D** = evaporator with distributor **H** = High Pressure
HD = High Pressure with distributor

Model S06, S07, S09, S12, S22, S62, S82, S85, S87, S93, S101,
 S182, S187, S202, S222, S404, S424, S606, S608, S727

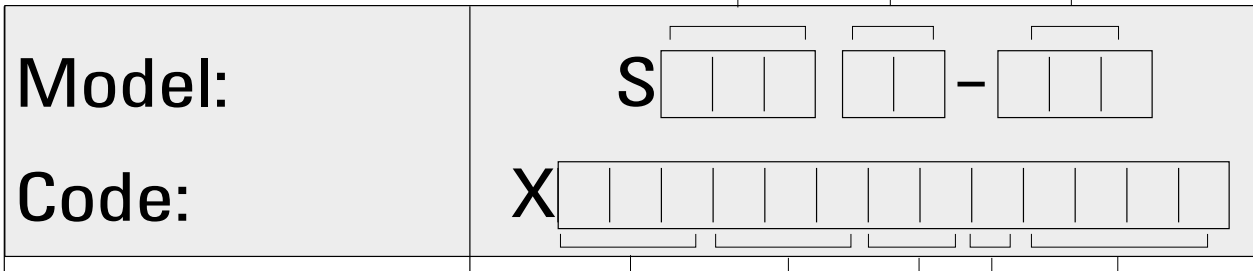

Model S06, S07, S09, S12, S22, S62, S82, S85, S87, S93, S101,
 S182, S187, S202, S222, S404, S424, S606, S608, S727

Numbers of plates

Configuration connections

Operating **Single circuit** **0** = evaporator condensor **1** = evaporator with distributor
2 = High Pressure **3** = High Pressure with distributor

Dual Circuit: **4** = Cross circuit refrigerant **5** = Cross circuit refrigerant with distributor
6 = High Pressure refrigerant **7** = High Pressure refrigerant plus distributor

Progressive number to identify size & type connections

PLEASE READ OPERATING AND INSTRUCTIONS MANUAL BEFORE USE

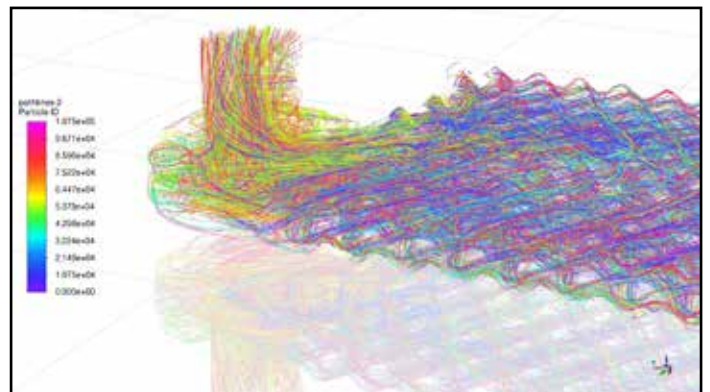
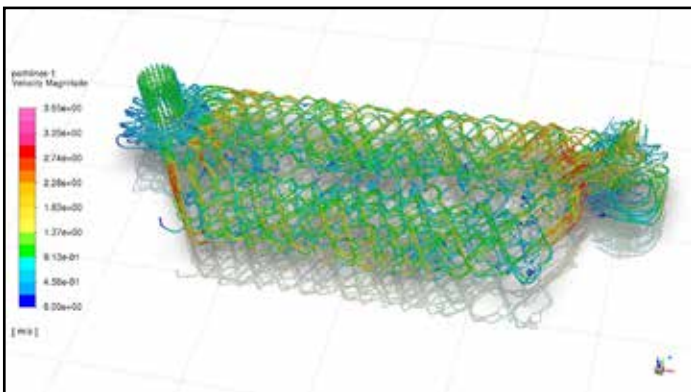

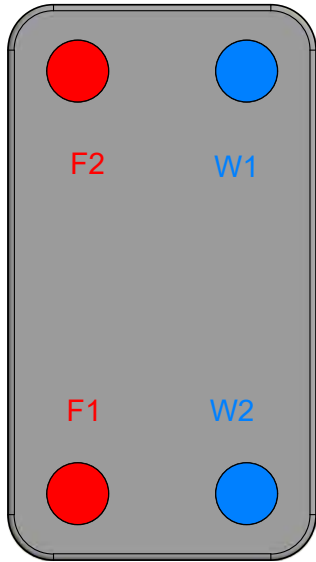

● = Circuit F

● = Circuit W

SINGLE
CIRCUIT

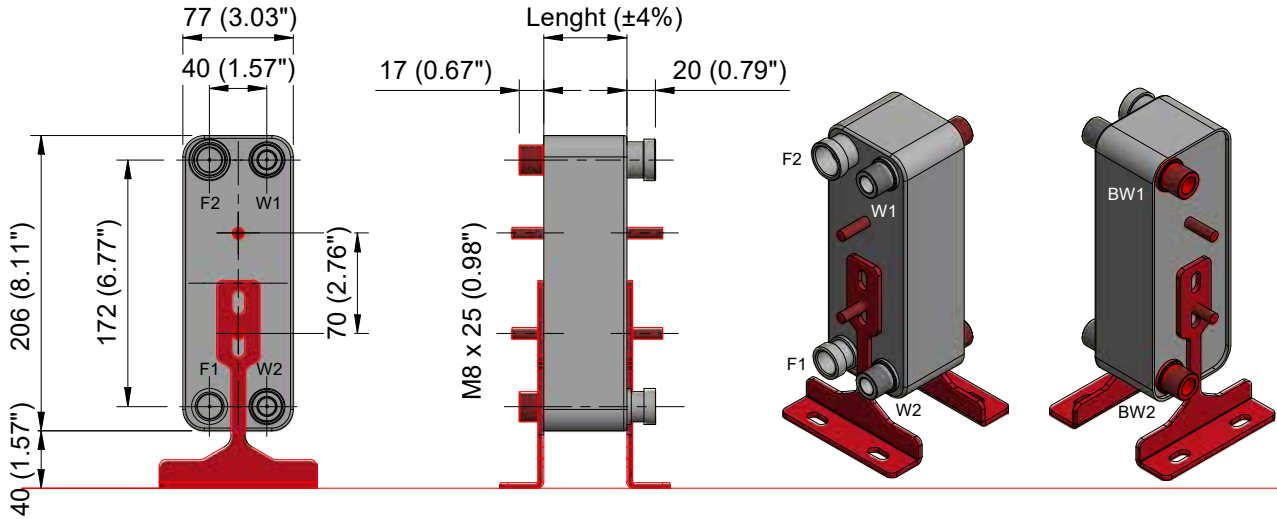

Optional: stud bolts and mounting feet

F1 INLET Refrigerant W1-BW1 INLET Secondary Fluid
 F2 OUTLET Refrigerant W2-BW2 OUTLET Secondary Fluid

SPECIFICATIONS	S06	S06H	CONNECTIONS TYPE			
PS (bar)	30	45	Soldering	Threaded M	Threaded F	Rotalock
TEMPERATURE RANGE (°C)	-100°C to +120°C	-100°C to +120°C	S6	C22	F22	R19
MAXIMUM CONNECTIONS AVAILABLE (mm)	18	18	S8	C27	IF22	R25
MAXIMUM FLOW RATE (m3/h)	3,2	3,2	S12	G22	IF6	
VOLUME / CHANNEL (liters)	0,0346	0,0346	S14	G27	IF8	
DIMENSIONS (mm)	80 x 211	80 x 211	S16	IC22		
LENGHT CALCULATION (mm)	N x 2,3 + 10	N x 2,3 + 10	S18	IC27		
WEIGHT CALCULATION (kg)	N x 0,06 + 0,5	N x 0,06 + 0,5	S19			
	SAME "H" DESIGN		S20			
			Standard connections: F1 S18 F2 S20 W1-W2 C22			
			FOR SPECIAL CONNECTIONS SEE PAGE 34 AND 35			

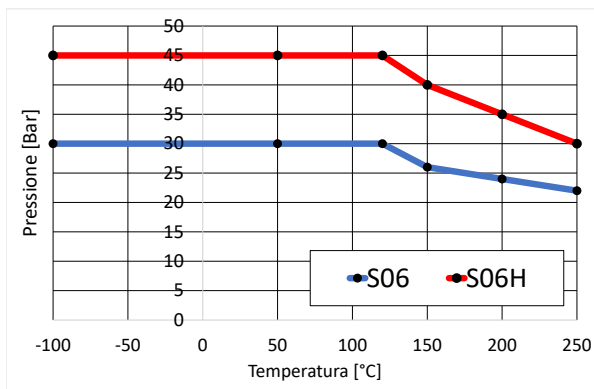

N Number of plates

LETTER TO IDENTIFY CONNECTIONS TYPE

- S** Soldering Connections
- C** Conical Male Gas Threaded Connections
- G** Cylindric Male Gas Threaded Connections
- F** Female Gas Threaded Connections
- R** Rotalock Connections Male

EXCHANGE PLATE MATERIAL Stainless Steel 316L

BRAZING MATERIAL Copper (Cu)

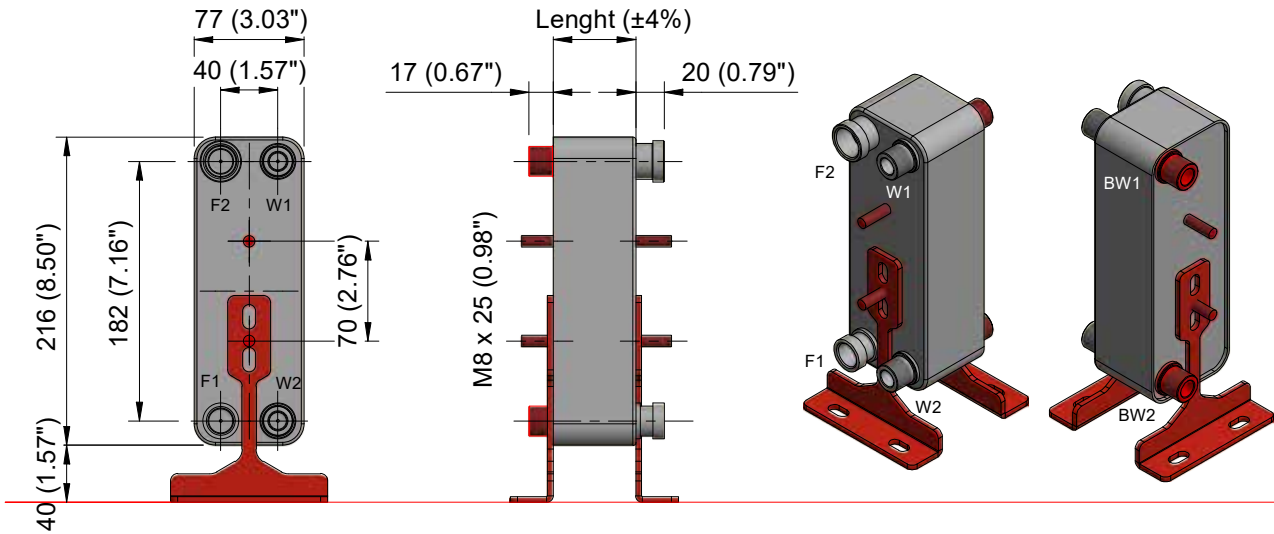

Optional: stud bolts and mounting feet

F1 INLET Refrigerant W1-BW1 INLET Secondary Fluid
 F2 OUTLET Refrigerant W2-BW2 OUTLET Secondary Fluid

SPECIFICATIONS	S07	S07H	CONNECTIONS TYPE			
PS (bar)	30	45	Soldering	Threaded M	Threaded F	Rotalock
TEMPERATURE RANGE (°C)	-100°C to +120°C	-100°C to +120°C	S6	C22	F22	R19
MAXIMUM CONNECTIONS AVAILABLE (mm)	18	18	S8	C27	IF22	R25
MAXIMUM FLOW RATE (m³/h)	3,2	3,2	S12	G22	IF6	
VOLUME / CHANNEL (liters)	0,036	0,036	S14	G27	IF8	
DIMENSIONS (mm)	80 x 221	80 x 221	S16	IC22		
LENGHT CALCULATION (mm)	N x 2,3 + 10	N x 2,3 + 10	S18	IC27		
WEIGHT CALCULATION (kg)	N x 0,07 + 0,5	N x 0,07 + 0,5	S19			
	SAME "H" DESIGN		S20			
			Standard connections: F1 S18 F2 S20 W1-W2 C22			
			FOR SPECIAL CONNECTIONS SEE PAGE 34 AND 35			

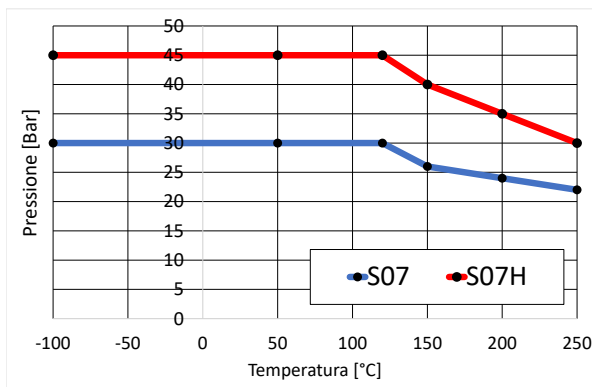

N Number of plates

LETTER TO IDENTIFY CONNECTIONS TYPE

- S** Soldering Connections
- C** Conical Male Gas Threaded Connections
- G** Cylindric Male Gas Threaded Connections
- F** Female Gas Threaded Connections
- R** Rotalock Connections Male

EXCHANGE PLATE MATERIAL Stainless Steel 316L

BRAZING MATERIAL Copper (Cu)

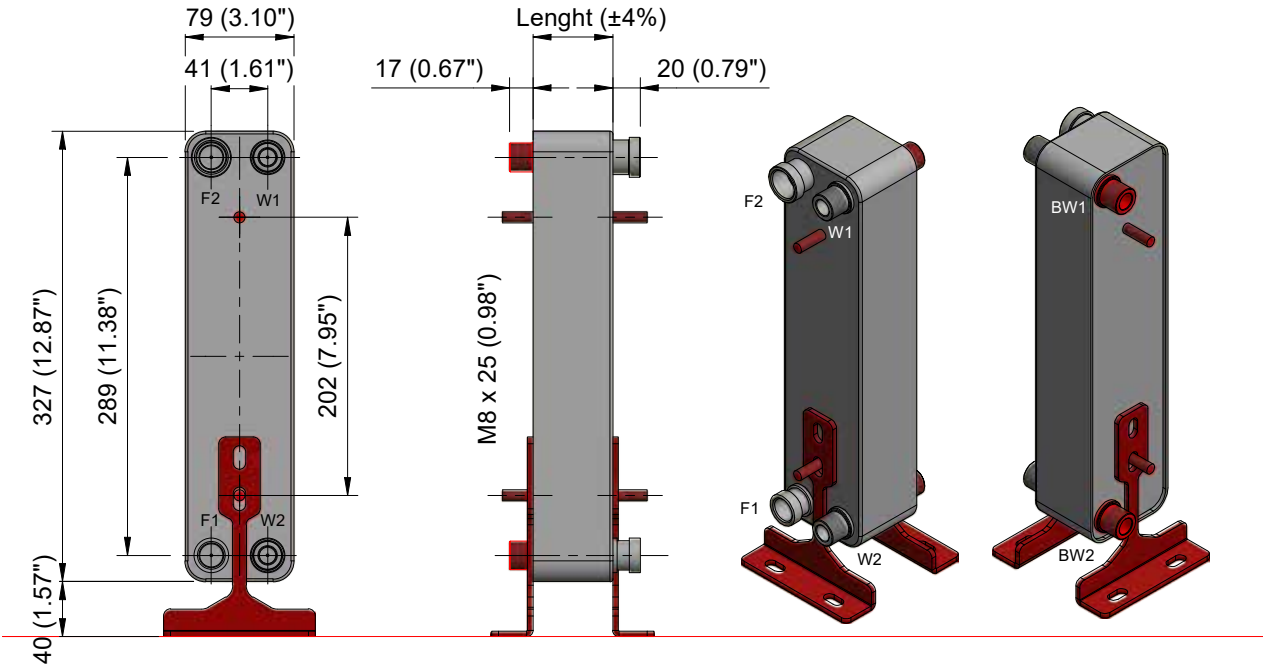

Optional: stud bolts and mounting feet

F1 INLET Refrigerant W1-BW1 INLET Secondary Fluid
 F2 OUTLET Refrigerant W2-BW2 OUTLET Secondary Fluid

SPECIFICATIONS	S09	S09H	CONNECTIONS TYPE			
			Soldering	Threaded M	Threaded F	Rotalock
PS (bar)	30	49				
TEMPERATURE RANGE (°C)	-100°C to +120°C	-100°C to +150°C	S6	C22	F22	R19
MAXIMUM CONNECTIONS AVAILABLE (mm)	18	18	S8	C27	IF22	R25
MAXIMUM FLOW RATE (m3/h)	3,2	3,2	S12	G22	IF6	
VOLUME / CHANNEL (liters)	0,054	0,054	S14	G27	IF8	
DIMENSIONS (mm)	80 x 328	80 x 328	S16	IC22		
LENGHT CALCULATION (mm)	$N \times 2,3 + 10$	$N \times 2,3 + 10$	S18	IC27		
WEIGHT CALCULATION (kg)	$N \times 0,08 + 1,1$	$N \times 0,08 + 1,1$	S19			
	SAME "H" DESIGN		S20			
			Standard connections: F1 S18 F2 S20 W1-W2 C22			
			FOR SPECIAL CONNECTIONS SEE PAGE 34 AND 35			

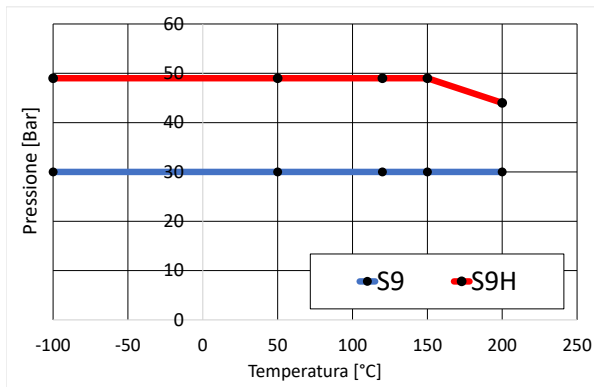

N Number of plates

LETTER TO IDENTIFY CONNECTIONS TYPE

- S** Soldering Connections
- C** Conical Male Gas Threaded Connections
- G** Cylindric Male Gas Threaded Connections
- F** Female Gas Threaded Connections
- R** Rotalock Connections Male

EXCHANGE PLATE MATERIAL Stainless Steel 316L

BRAZING MATERIAL Copper (Cu)

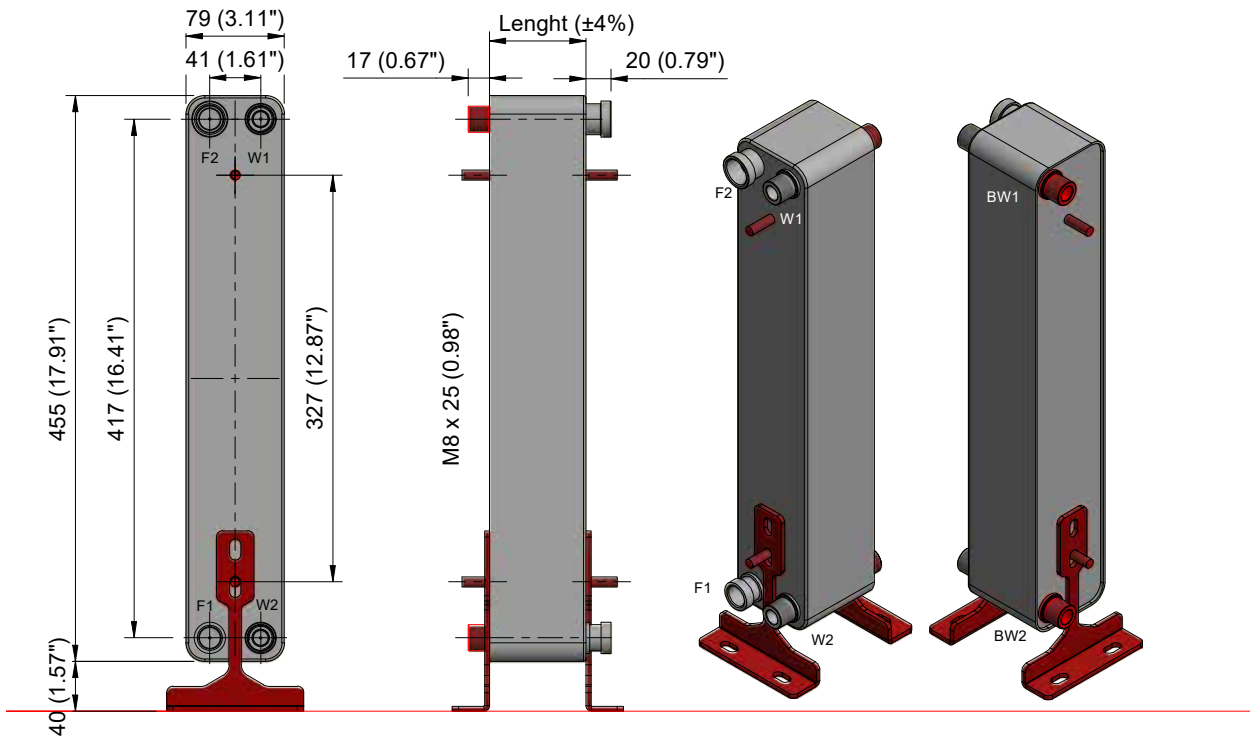

Optional: stud bolts and mounting feet

F1 INLET Refrigerant W1-BW1 INLET Secondary Fluid
 F2 OUTLET Refrigerant W2-BW2 OUTLET Secondary Fluid

SPECIFICATIONS	S22	S22H
PS (bar)	30	45
TEMPERATURE RANGE (°C)	-100°C to +120°C	-100°C to +120°C
MAXIMUM CONNECTIONS AVAILABLE (mm)	18	18
MAXIMUM FLOW RATE (m3/h)	5,7	5,7
VOLUME / CHANNEL (liters)	0,065	0,065
DIMENSIONS (mm)	80 x 456	80 x 456
LENGHT CALCULATION (mm)	$N \times 2,3 + 12$	$N \times 2,3 + 16$
WEIGHT CALCULATION (kg)	$N \times 0,10 + 1,8$	$N \times 0,10 + 4$

CONNECTIONS TYPE			
Soldering	Threaded M	Threaded F	Rotalock
S6	C22	F22	R19
S8	C27	IF22	R25
S12	G22	IF6	
S14	G27	IF8	
S16	IC22		
S18	IC27		
S19			
S20			
Standard connections: F1 S18 F2 S20 W1-W2 C22			
FOR SPECIAL CONNECTIONS SEE PAGE 34 AND 35			

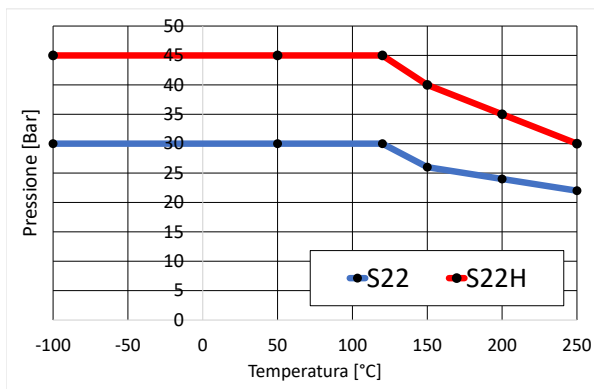

N Number of plates

LETTER TO IDENTIFY CONNECTIONS TYPE

- S** Soldering Connections
- C** Conical Male Gas Threaded Connections
- G** Cylindric Male Gas Threaded Connections
- F** Female Gas Threaded Connections
- R** Rotalock Connections Male

EXCHANGE PLATE MATERIAL Stainless Steel 316L

BRAZING MATERIAL Copper (Cu)

S12-S12M

SINGLE CIRCUIT

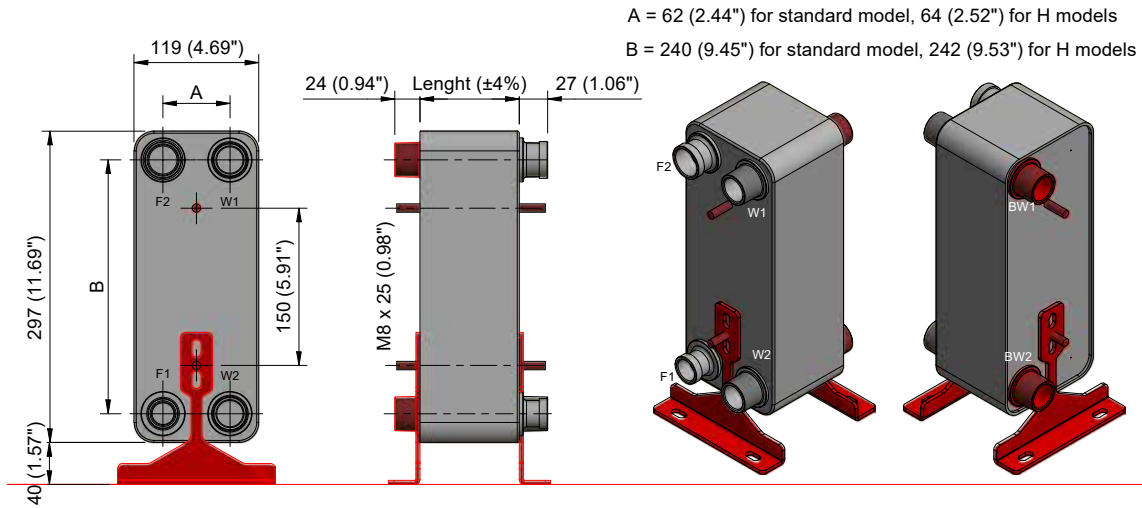

Optional: stud bolts and mounting feet

F1 INLET Refrigerant W1-BW1 INLET Secondary Fluid
 F2 OUTLET Refrigerant W2-BW2 OUTLET Secondary Fluid

SPECIFICATIONS	S12	S12H
PS (bar)	30	49
TEMPERATURE RANGE (°C)	-100°C to +120°C	-100°C to +150°C
MAXIMUM CONNECTIONS AVAILABLE (mm)	30,1	30,1
MAXIMUM FLOW RATE (m3/h)	9,7	9,7
VOLUME / CHANNEL (liters)	0,071	0,071
DIMENSIONS (mm)	120 x 298	120 x 298
LENGHT CALCULATION (mm)	$N \times 2,3 + 12$	$N \times 2,3 + 16$
WEIGHT CALCULATION (kg)	$N \times 0,1 + 1,5$	$N \times 0,1 + 4$

CONNECTIONS TYPE				
Soldering	Threaded M	Threaded F	Grooved	Rotalock
S6	C22	F22	V32	R19
S8	IC22	F27	BV32	R25
S12	C27	F32	V40	R32
S14	IC27	F42	BV40	R44
S16	C32	IF22		
S18	IC32	IF27		
S19	C42	IF32		
S22	IC42	IF42		
S28	G22			
S35	G27			
	G32			
	G42			
Standard Connections: F1 S22 F2 S28 W1-W2 C32				
FOR SPECIAL CONNECTIONS SEE PAGE 34 AND 35				

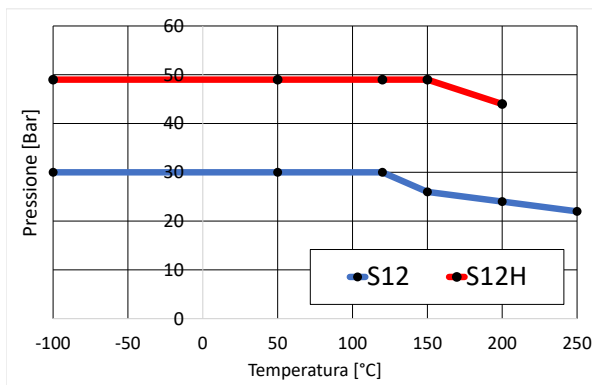

N Number of plates

LETTER TO IDENTIFY CONNECTIONS TYPE

- S** Soldering Connections
- C** Conical Male Gas Threaded Connections
- G** Cylindric Male Gas Threaded Connections
- F** Female Gas Threaded Connections
- V-BV** Grooved System for Standard Flexible Coupling
- R** Rotalock Connections Male

EXCHANGE PLATE MATERIAL Stainless Steel 316L

BRAZING MATERIAL Copper (Cu)

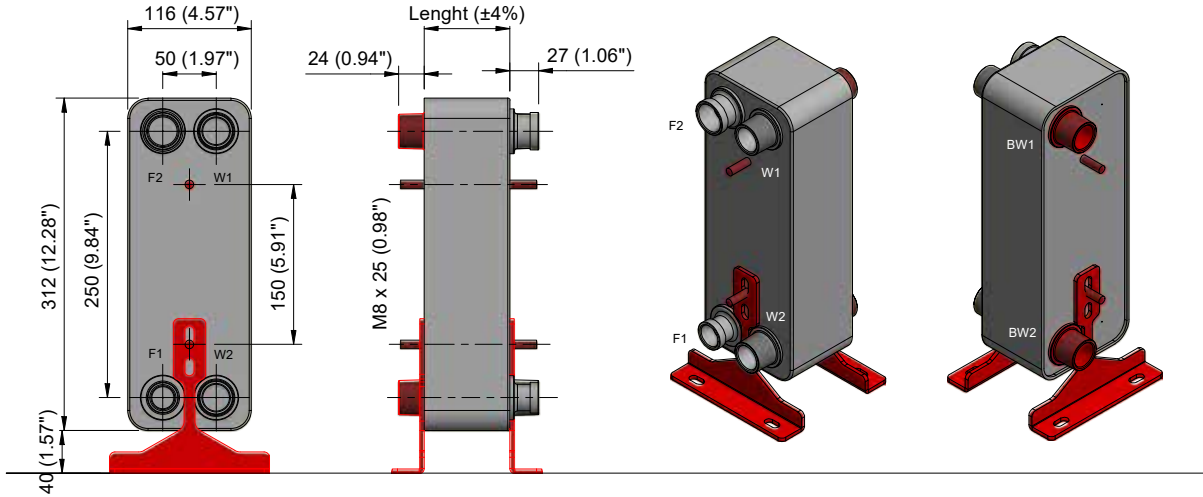

Optional: stud bolts and mounting feet

F1 INLET Refrigerant W1-BW1 INLET Secondary Fluid
 F2 OUTLET Refrigerant W2-BW2 OUTLET Secondary Fluid

SPECIFICATIONS	S16	S16H
PS (bar)	30	45
TEMPERATURE RANGE (°C)	-100°C to +120°C	-100°C to +120°C
MAXIMUM CONNECTIONS AVAILABLE (mm)	34	34
MAXIMUM FLOW RATE (m3/h)	9,7	9,7
VOLUME / CHANNEL (liters)	0,08	0,08
DIMENSIONS (mm)	116 x 312	116 x 312
LENGHT CALCULATION (mm)	$N \times 2,3 + 12$	$N \times 2,3 + 16$
WEIGHT CALCULATION (kg)	$N \times 0,1 + 1,5$	$N \times 0,1 + 4$

CONNECTIONS TYPE				
Soldering	Threaded M	Threaded F	Grooved	Rotalock
S6	C22	F22	V32	R19
S8	IC22	F27	BV32	R25
S12	C27	F32	V40	R32
S14	IC27	IF22	BV40	
S16	C32	IF27		
S18	IC32	IF32		
S19	G22			
S22	G27			
S28	G32			
S35				
Standard Connections: F1 S22 F2 S28 W1-W2 C32				
FOR SPECIAL CONNECTIONS SEE PAGE 34 AND 35				

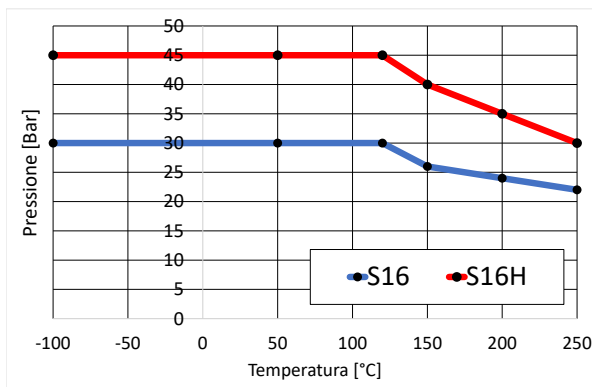

N Number of plates

LETTER TO IDENTIFY CONNECTIONS TYPE

- S** Soldering Connections
- C** Conical Male Gas Threaded Connections
- G** Cylindric Male Gas Threaded Connections
- F** Female Gas Threaded Connections
- V-BV** Grooved System for Standard Flexible Coupling
- R** Rotalock Connections Male

EXCHANGE PLATE MATERIAL Stainless Steel 316L
 BRAZING MATERIAL Copper (Cu)

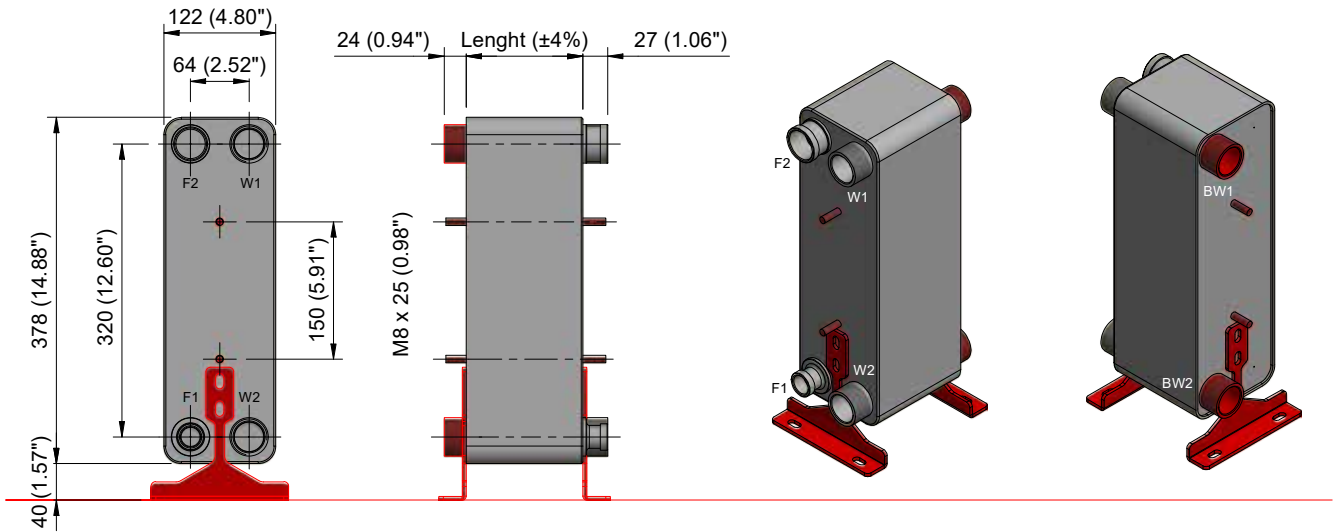

Optional: stud bolts and mounting feet

F1 INLET Refrigerant W1-BW1 INLET Secondary Fluid
 F2 OUTLET Refrigerant W2-BW2 OUTLET Secondary Fluid

SPECIFICATIONS	S62	S62H
PS (bar)	30	49
TEMPERATURE RANGE (°C)	-100°C to +120°C	-100°C to +150°C
MAXIMUM CONNECTIONS AVAILABLE (mm)	38,9	38,9
MAXIMUM FLOW RATE (m3/h)	15,9	15,9
VOLUME / CHANNEL (liters)	0,08	0,08
DIMENSIONS (mm)	122 x 378	122 x 378
LENGHT CALCULATION (mm)	N x 2,15 + 12	N x 2,15 + 16
WEIGHT CALCULATION (kg)	N x 0,12 + 2	N x 0,12 + 4

CONNECTIONS TYPE				
Soldering	Threaded M	Threaded F	Grooved	Rotalock
S6	C22	F22	V32	R19
S8	IC22	F27	BV32	R25
S12	C27	F32	V40	R32
S14	IC27	F42	BV40	R44
S16	C32	IF22		
S18	IC32	IF27		
S19	C42	IF32		
S22	IC42	IF42		
S28	G22			
S35	G27			
	G32			
	G42			

Standard Connections:
 F1 S22 F2 S35 W1-W2 C42

FOR SPECIAL CONNECTIONS
 SEE PAGE 34 AND 35

Weight of connections not included

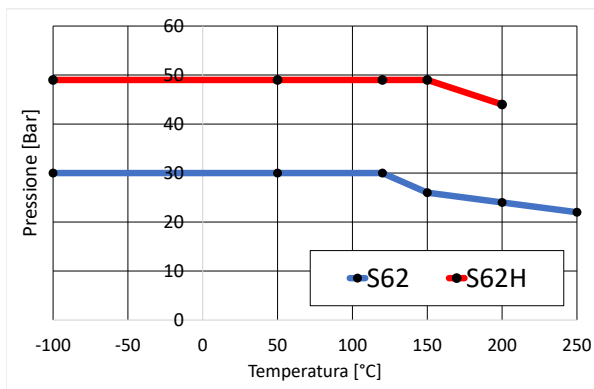

N Number of plates

LETTER TO IDENTIFY CONNECTIONS TYPE

- S** Soldering Connections
- C** Conical Male Gas Threaded Connections
- G** Cylindric Male Gas Threaded Connections
- F** Female Gas Threaded Connections
- V-BV** Grooved System for Standard Flexible Coupling
- R** Rotalock Connections Male

EXCHANGE PLATE MATERIAL Stainless Steel 316L

BRAZING MATERIAL Copper (Cu)

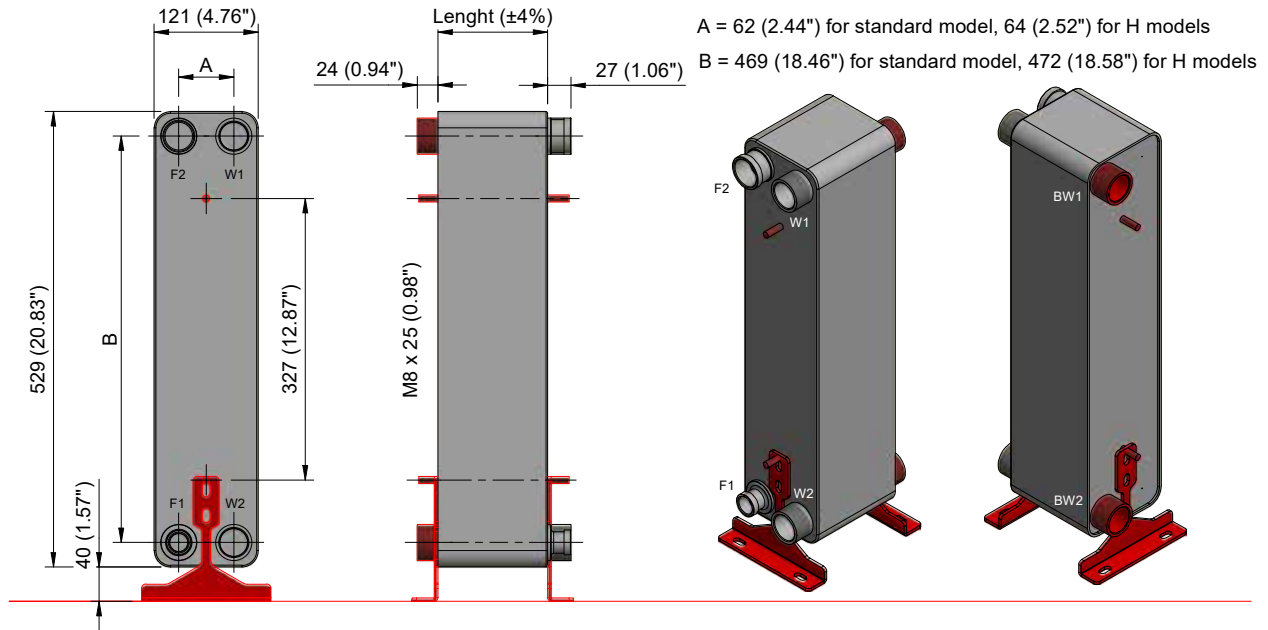

Optional: stud bolts and mounting feet

F1 INLET Refrigerant W1-BW1 INLET Secondary Fluid
 F2 OUTLET Refrigerant W2-BW2 OUTLET Secondary Fluid

SPECIFICATIONS	S82	S82H
PS (bar)	30	45
TEMPERATURE RANGE (°C)	-100°C to +120°C	-100°C to +120°C
MAXIMUM CONNECTIONS AVAILABLE (mm)	38,9	38,9
MAXIMUM FLOW RATE (m3/h)	15,9	15,9
VOLUME / CHANNEL (liters)	0,122	0,122
DIMENSIONS (mm)	122 x 530	122 x 530
LENGHT CALCULATION (mm)	$N \times 2,15 + 11$	$N \times 2,15 + 15$
WEIGHT CALCULATION (kg)	$N \times 0,17 + 2$	$N \times 0,17 + 6$

CONNECTIONS TYPE				
Soldering	Threaded M	Threaded F	Grooved	Rotalock
S6	C22	F22	V32	R19
S8	IC22	F27	BV32	R25
S12	C27	F32	V40	R32
S14	IC27	F42	BV40	R44
S16	C32	IF22		
S18	IC32	IF27		
S19	C42	IF32		
S22	IC42	IF42		
S28	G22			
S35	G27			
	G32			
	G42			
Standard Connections: F1 S22 F2 S35 W1-W2 C42				
FOR SPECIAL CONNECTIONS SEE PAGE 34 AND 35				

Weight of connections not included

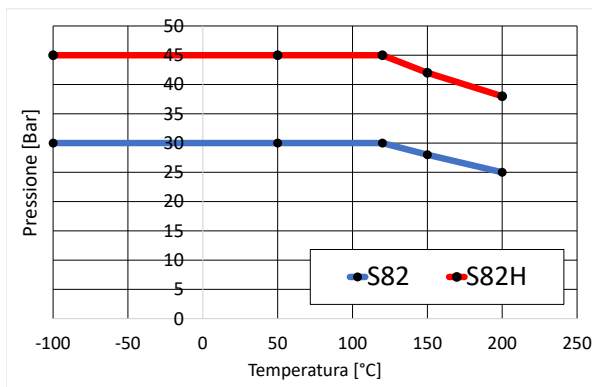

N Number of plates

LETTER TO IDENTIFY CONNECTIONS TYPE

- S** Soldering Connections
- C** Conical Male Gas Threaded Connections
- G** Cylindric Male Gas Threaded Connections
- F** Female Gas Threaded Connections
- V-BV** Grooved System for Standard Flexible Coupling
- R** Rotalock Connections Male

EXCHANGE PLATE MATERIAL Stainless Steel 316L
 BRAZING MATERIAL Copper (Cu)

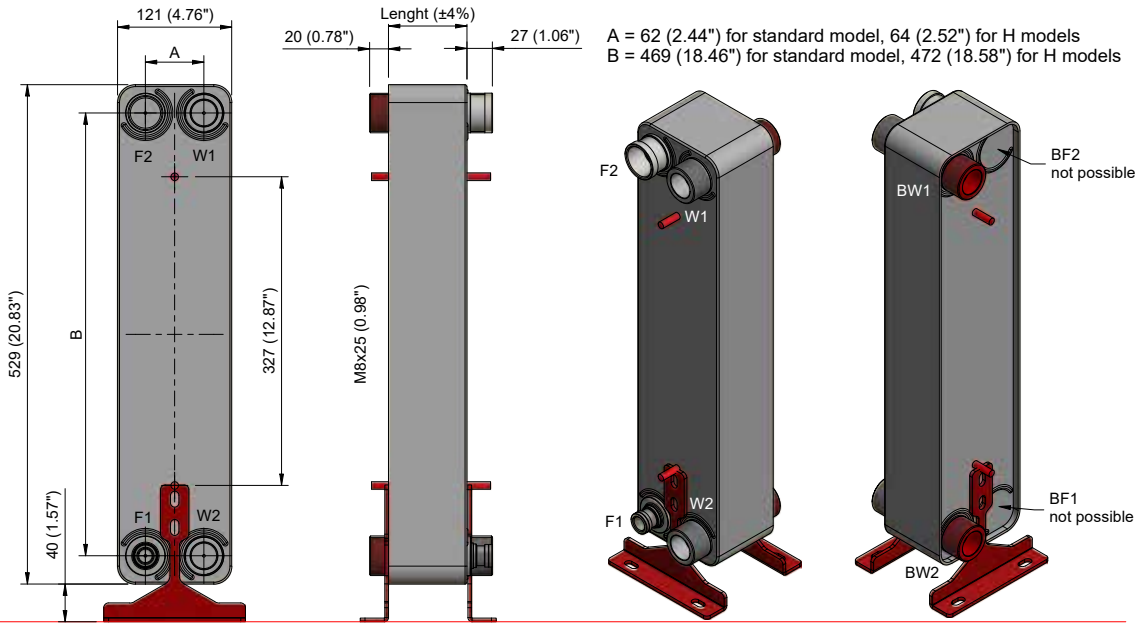

Optional: stud bolts and mounting feet

F1 INLET Refrigerant W1-BW1 INLET Secondary Fluid
 F2 OUTLET Refrigerant W2-BW2 OUTLET Secondary Fluid

SPECIFICATIONS	S85	S85H
PS (bar)	30	49
TEMPERATURE RANGE (°C)	-100°C to +150°C	-100°C to +150°C
MAXIMUM CONNECTIONS AVAILABLE (mm)	38,9	38,9
MAXIMUM FLOW RATE (m3/h)	15,9	15,9
VOLUME / CHANNEL (liters)	0,098	0,098
DIMENSIONS (mm)	122 x 530	122 x 530
LENGHT CALCULATION (mm)	$N \times 1,80 + 11$	$N \times 1,80 + 11$
WEIGHT CALCULATION (kg)	$N \times 0,17 + 2$	$N \times 0,17 + 6$

CONNECTIONS TYPE				
Soldering	Threaded M	Threaded F	Grooved	Rotalock
S6	C22	F22	V32	R19
S8	IC22	F27	BV32	R25
S12	C27	F32	V40	R32
S14	IC27	F42	BV40	R44
S16	C32	IF22		
S18	IC32	IF27		
S19	C42	IF32		
S22	IC42	IF42		
S28	G22			
S35	G27			
	G32			
	G42			

Standard Connections:
 F1 S16 F2 S35 W1-W2 C42
 FOR SPECIAL CONNECTIONS SEE PAGE 32 AND 33

Weight of connections not included

To optimize the evaporator S87D-S87HD performance refer to Onda' software HTC Brazed – nozzles at additional accessories page

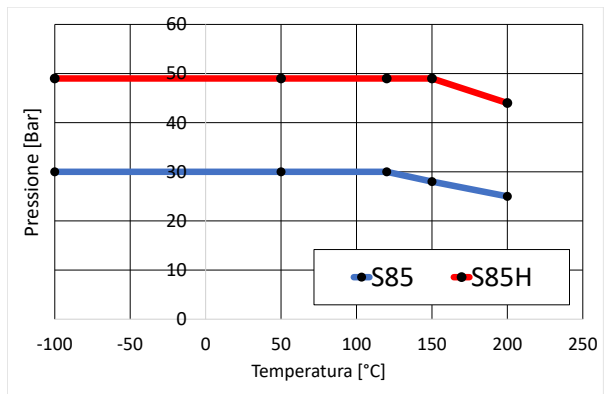

- N** Number of plates
- LETTER TO IDENTIFY CONNECTIONS TYPE**
- S** Soldering Connections
- C** Conical Male Gas Threaded Connections
- G** Cylindric Male Gas Threaded Connections
- F** Female Gas Threaded Connections
- V-BV** Grooved System for Standard Flexible Coupling
- R** Rotalock Connections Male
- EXCHANGE PLATE MATERIAL** Stainless Steel 316L
- BRAZING MATERIAL** Copper (Cu)

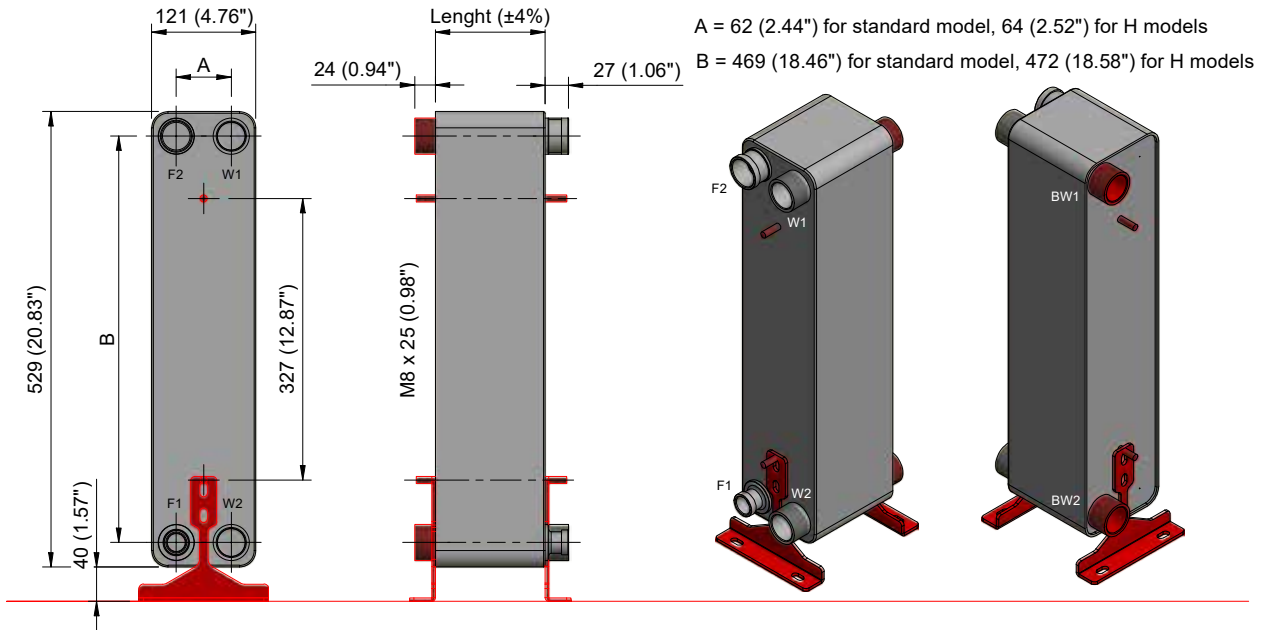

A = 62 (2.44") for standard model, 64 (2.52") for H models

B = 469 (18.46") for standard model, 472 (18.58") for H models

Optional: stud bolts and mounting feet

F1 INLET Refrigerant W1-BW1 INLET Secondary Fluid
 F2 OUTLET Refrigerant W2-BW2 OUTLET Secondary Fluid

SPECIFICATIONS	S87	S87H
PS (bar)	30	49
TEMPERATURE RANGE (°C)	-100°C to +120°C	-100°C to +150°C
MAXIMUM CONNECTIONS AVAILABLE (mm)	38,9	38,9
MAXIMUM FLOW RATE (m3/h)	15,9	15,9
VOLUME / CHANNEL (liters)	0,122	0,122
DIMENSIONS (mm)	122 x 530	122 x 530
LENGHT CALCULATION (mm)	N x 2,15 + 11	N x 2,15 + 15
WEIGHT CALCULATION (kg)	N x 0,17 + 2	N x 0,17 + 6

CONNECTIONS TYPE				
Soldering	Threaded M	Threaded F	Grooved	Rotalock
S6	C22	F22	V32	R19
S8	IC22	F27	BV32	R25
S12	C27	F32	V40	R32
S14	IC27	F42	BV40	R44
S16	C32	IF22		
S18	IC32	IF27		
S19	C42	IF32		
S22	IC42	IF42		
S28	G22			
S35	G27			
	G32			
	G42			

Standard Connections:
 F1 S16 F2 S35 W1-W2 C42
 FOR SPECIAL CONNECTIONS SEE PAGE 32 AND 33

Weight of connections not included

To optimize the evaporator S87D-S87HD performance refer to Onda' software HTC Brazed - nozzles at additional accessories page

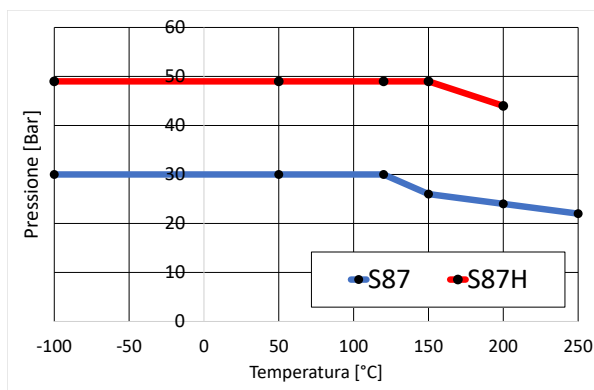

N Number of plates

LETTER TO IDENTIFY CONNECTIONS TYPE

- S** Soldering Connections
- C** Conical Male Gas Threaded Connections
- G** Cylindric Male Gas Threaded Connections
- F** Female Gas Threaded Connections
- V-BV** Grooved System for Standard Flexible Coupling
- R** Rotalock Connections Male

EXCHANGE PLATE MATERIAL Stainless Steel 316L
 BRAZING MATERIAL Copper (Cu)

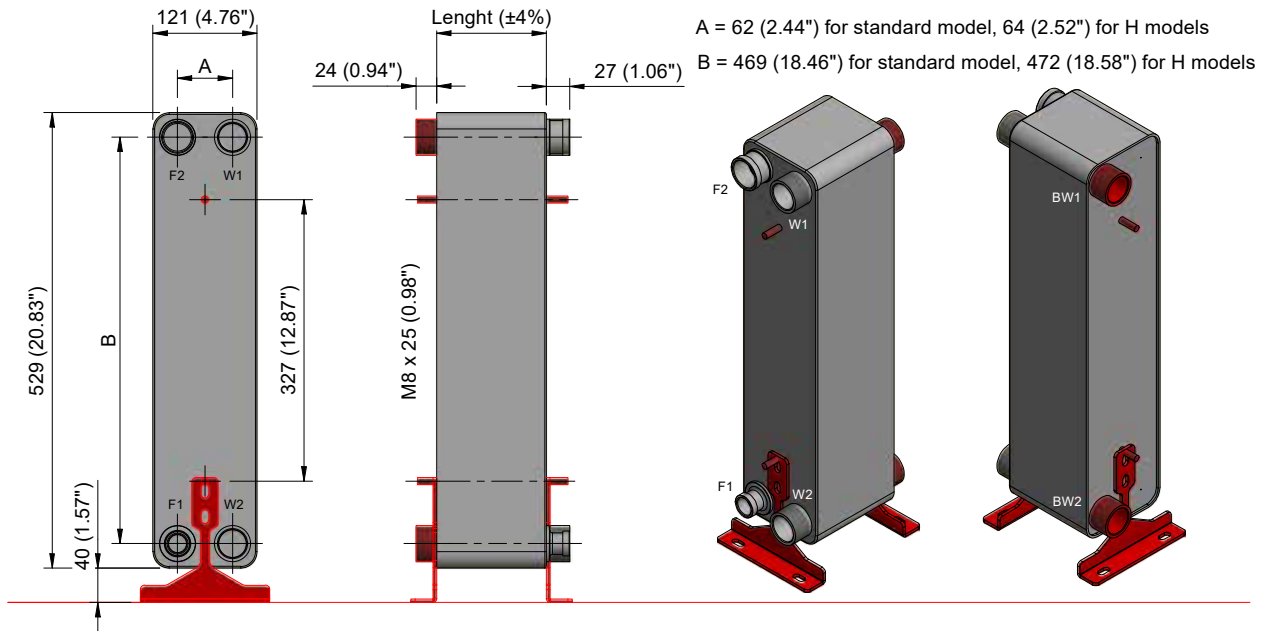

Optional: stud bolts and mounting feet

F1 INLET Refrigerant W1-BW1 INLET Secondary Fluid
 F2 OUTLET Refrigerant W2-BW2 OUTLET Secondary Fluid

SPECIFICATIONS	S93	S93H	CONNECTIONS TYPE				
			Soldering	Threaded M	Threaded F	Grooved	Rotalock
PS (bar)	30	49	S6	C22	F22	V32	R19
TEMPERATURE RANGE (°C)	-100°C to +120°C	-100°C to +150°C	S8	IC22	F27	BV32	R25
MAXIMUM CONNECTIONS AVAILABLE (mm)	38,9	38,9	S12	C27	F32	V40	R32
MAXIMUM FLOW RATE (m3/h)	15,9	15,9	S14	IC27	F42	BV40	R44
VOLUME / CHANNEL (liters) F1-F2	0,11	0,11	S16	C32	IF22		
VOLUME / CHANNEL (liters) W1-W2	0,135	0,135	S18	IC32	IF27		
DIMENSIONS (mm)	122 x 530	122 x 530	S19	C42	IF32		
LENGHT CALCULATION (mm)	N x 2,15 + 11	N x 2,15 + 15	S22	IC42	IF42		
WEIGHT CALCULATION (kg)	N x 0,17 + 2	N x 0,17 + 6	S28	G22			
			S35	G27			
				G32			
				G42			
			Standard Connections: F1 S16 F2 S35 W1-W2 C42				
			FOR SPECIAL CONNECTIONS SEE PAGE 32 AND 33				

Weight of connections not included

To optimize the evaporator S93D-S93HD performance refer to Onda' software HTC Brazed - nozzles at additional accessories page

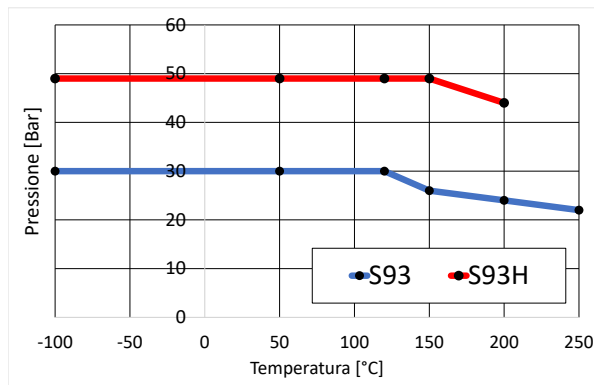

N Number of plates

LETTER TO IDENTIFY CONNECTIONS TYPE

- S Soldering Connections
- C Conical Male Gas Threaded Connections
- G Cylindric Male Gas Threaded Connections
- F Female Gas Threaded Connections
- V-BV Grooved System for Standard Flexible Coupling
- R Rotalock Connections Male

EXCHANGE PLATE MATERIAL Stainless Steel 316L
 BRAZING MATERIAL Copper (Cu)

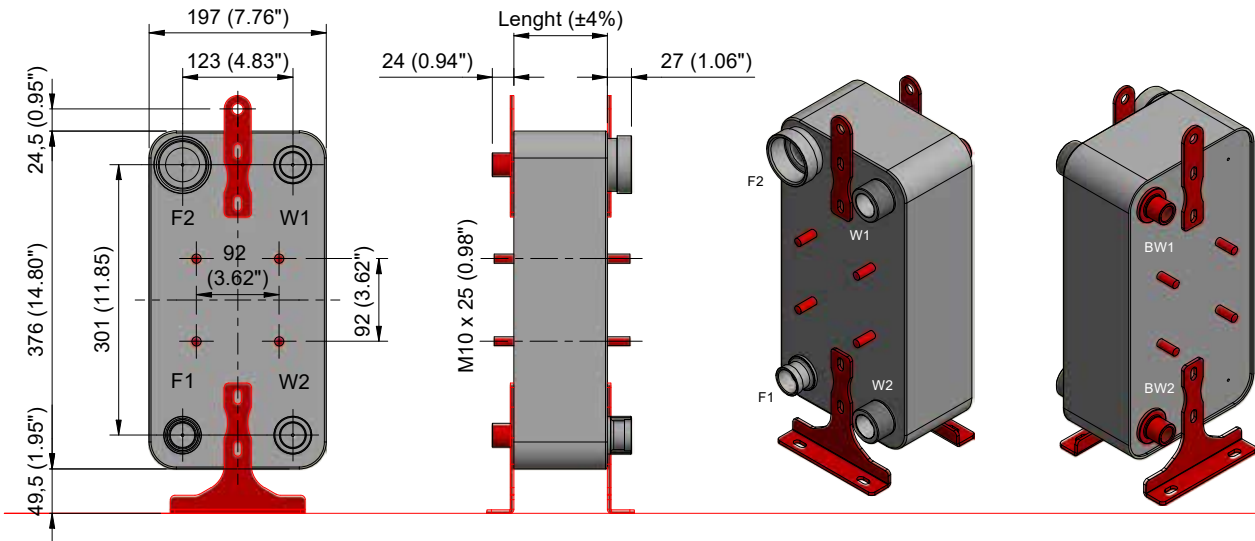

Optional: stud bolts and mounting feet

F1 INLET Refrigerant W1-BW1 INLET Secondary Fluid
 F2 OUTLET Refrigerant W2-BW2 OUTLET Secondary Fluid

SPECIFICATIONS	S101	S101H	CONNECTIONS TYPE				
PS (bar)	30	45	Soldering	Threaded M	Threaded F	Grooved	Rotalock
TEMPERATURE RANGE (°C)	-100°C to +120°C	-100°C to +120°C	S22	C32	F27	V32	R32
MAXIMUM CONNECTIONS AVAILABLE (mm)	42	42	S28	C42	F32	V40	R44
MAXIMUM FLOW RATE (m3/h)	15,9	15,9	S35	G32	F42		R58
VOLUME / CHANNEL (liters)	0,130	0,130	S42	G42	IF27		
DIMENSIONS (mm)	197 x 376	197 x 376	S50	IC32	IF32		
LENGHT CALCULATION (mm)	N x 2,20 + 14	N x 2,20 + 14		IC42	IF42		
WEIGHT CALCULATION (kg)	N x 0,26 + 9	N x 0,26 + 9	Standard Connections: F1 S35 F2 S50 W1-W2 C42				
	SAME "H" DESIGN		FOR SPECIAL CONNECTIONS SEE PAGE 34 AND 35				

Weight of connections not included

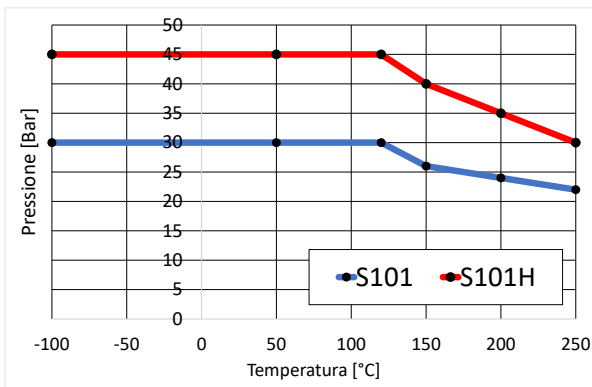

N Number of plates

LETTER TO IDENTIFY CONNECTIONS TYPE

- S** Soldering Connections
- C** Conical Male Gas Threaded Connections
- G** Cylindric Male Gas Threaded Connections
- F** Female Gas Threaded Connections
- V-BV** Grooved System for Standard Flexible Coupling
- R** Rotalock Connections Male

EXCHANGE PLATE MATERIAL Stainless Steel 316L

BRAZING MATERIAL Copper (Cu)

S182-S182M SINGLE CIRCUIT

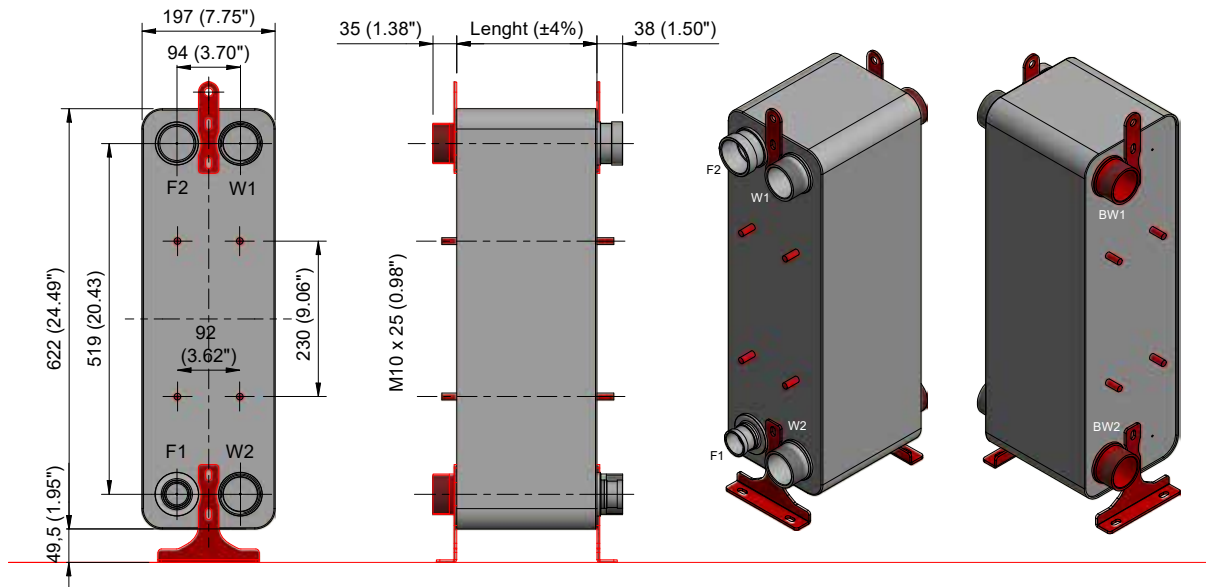

Optional: stud bolts and mounting feet

F1 INLET Refrigerant W1-BW1 INLET Secondary Fluid
 F2 OUTLET Refrigerant W2-BW2 OUTLET Secondary Fluid

SPECIFICATIONS	S182	S182H
PS (bar)	30	49
TEMPERATURE RANGE (°C)	-100°C to +120°C	-100°C to +150°C
MAXIMUM CONNECTIONS AVAILABLE (mm)	57	57
MAXIMUM FLOW RATE (m3/h)	38,9	38,9
VOLUME / CHANNEL (liters)	0,269	0,269
DIMENSIONS (mm)	197 x 622	197 x 622
LENGHT CALCULATION (mm)	$N \times 2,35 + 18$	$N \times 2,35 + 18$
WEIGHT CALCULATION (kg)	$N \times 0,36 + 12$	$N \times 0,36 + 12$
	SAME "H" DESIGN	

Weight of connections not included

CONNECTIONS TYPE					
Soldering	Threaded M	Threaded F	Grooved	Rotalock	Flanges
S22	C48	F48	V50	R32	CF66*
S28	IC48	F60	V65	R44	
S35	C60	IF48		R58	
S42	IC60	IF60			
S54	IC70				
S60	G48 G60 G70				
Standard Connections: F1 S35 F2 S54 W1-W2 C60 FOR SPECIAL CONNECTIONS SEE PAGE 34 AND 35					

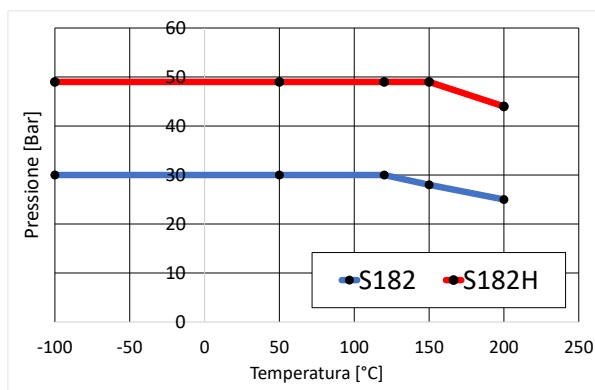

N Number of plates * ONLY IN W1/W2

LETTER TO IDENTIFY CONNECTIONS TYPE

- S** Soldering Connections
- C** Conical Male Gas Threaded Connections
- G** Cylindric Male Gas Threaded Connections
- F** Female Gas Threaded Connections
- V-BV** Grooved System for Standard Flexible Coupling
- R** Rotalock Connections Male

EXCHANGE PLATE MATERIAL Stainless Steel 316L
 BRAZING MATERIAL Copper (Cu)

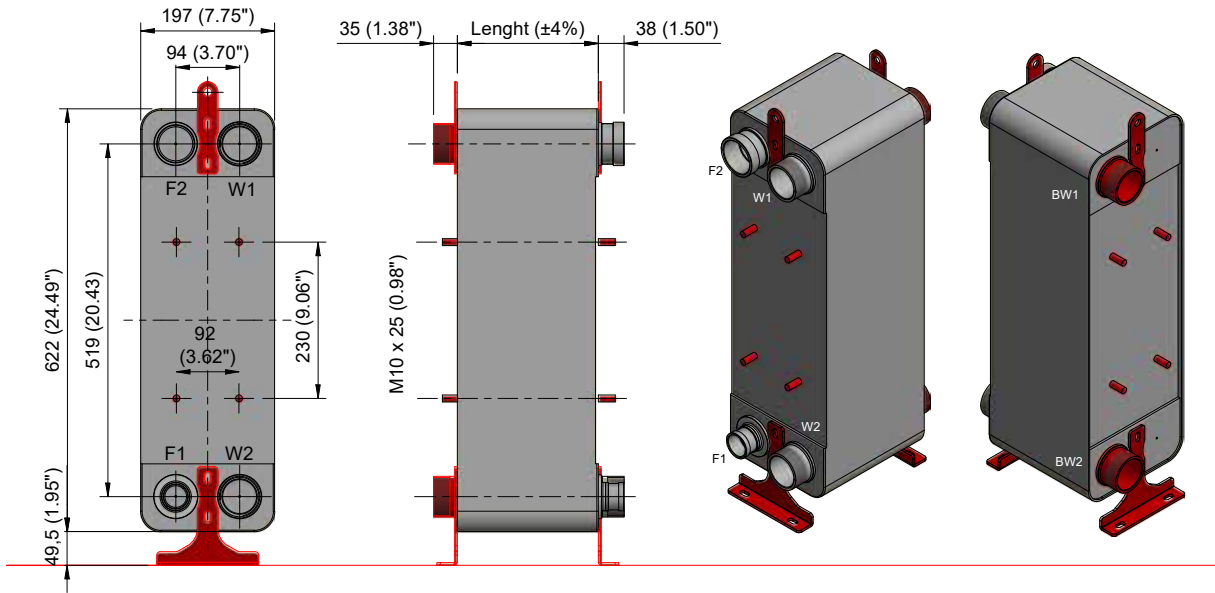

Optional: stud bolts and mounting feet

F1 INLET Refrigerant W1-BW1 INLET Secondary Fluid
 F2 OUTLET Refrigerant W2-BW2 OUTLET Secondary Fluid

SPECIFICATIONS	S187	S187H
PS (bar)	30	49
TEMPERATURE RANGE (°C)	-100°C to +150°C	-100°C to +150°C
MAXIMUM CONNECTIONS AVAILABLE (mm)	57	57
MAXIMUM FLOW RATE (m3/h)	56	56
VOLUME / CHANNEL (liters)	0,24	0,24
DIMENSIONS (mm)	197 x 622	197 x 622
LENGHT CALCULATION (mm)	$N \times 2,15 + 22$	$N \times 2,15 + 22$
WEIGHT CALCULATION (kg)	$N \times 0,36 + 12$	$N \times 0,36 + 12$
	SAME "H" DESIGN	

Weight of connections not included

CONNECTIONS TYPE					
Soldering	Threaded M	Threaded F	Grooved	Rotalock	Flanges
S22	C48	F48	V50	R32	CF66*
S28	IC48	F60	V65	R44	
S35	C60	IF48		R58	
S42	IC60	IF60			
S54	IC70				
S60	G48 G60 G70				
Standard Connections: F1 S35 F2 S54 W1-W2 C60 FOR SPECIAL CONNECTIONS SEE PAGE 34 AND 35					

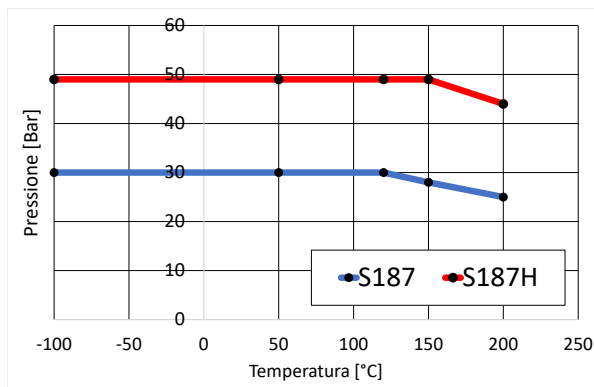

N Number of plates * ONLY IN W1/W2

LETTER TO IDENTIFY CONNECTIONS TYPE

- S** Soldering Connections
- C** Conical Male Gas Threaded Connections
- G** Cylindric Male Gas Threaded Connections
- F** Female Gas Threaded Connections
- V-BV** Grooved System for Standard Flexible Coupling
- R** Rotalock Connections Male

EXCHANGE PLATE MATERIAL Stainless Steel 316L
 BRAZING MATERIAL Copper (Cu)

S202-S202M SINGLE CIRCUIT

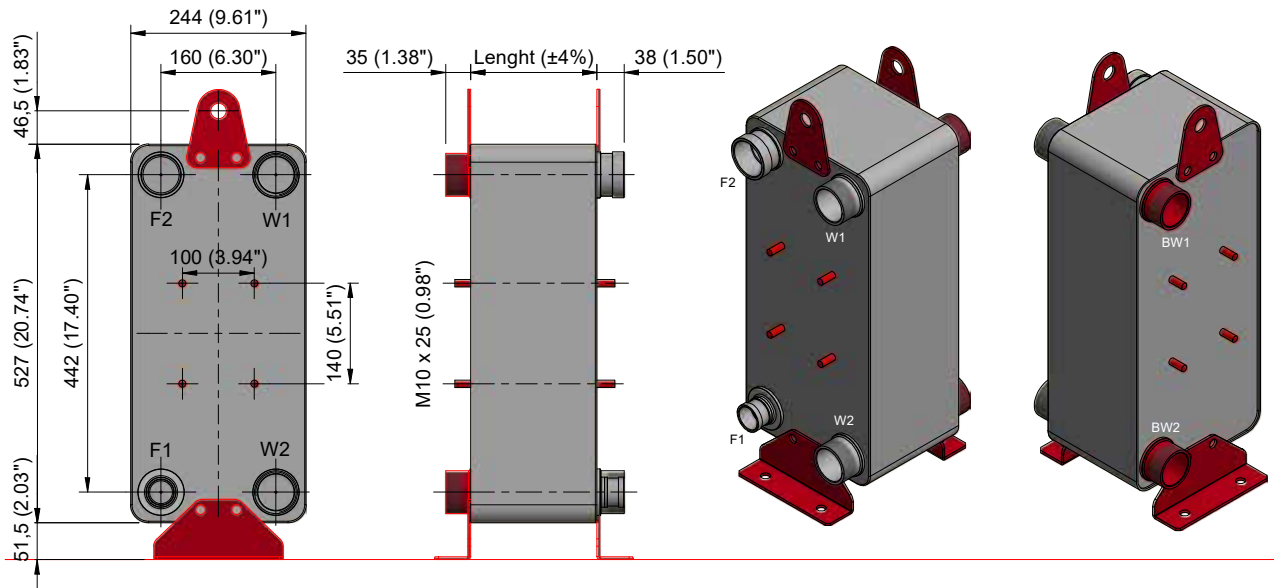

Optional: stud bolts and mounting feet

F1 INLET Refrigerant W1-BW1 INLET Secondary Fluid
 F2 OUTLET Refrigerant W2-BW2 OUTLET Secondary Fluid

SPECIFICATIONS	S202	S202H
PS (bar)	30	49
TEMPERATURE RANGE (°C)	-100°C to +120°C	-100°C to +150°C
MAXIMUM CONNECTIONS AVAILABLE (mm)	57	57
MAXIMUM FLOW RATE (m3/h)	38,9	38,9
VOLUME / CHANNEL (liters)	0,269	0,269
DIMENSIONS (mm)	245 x 527	245 x 527
LENGHT CALCULATION (mm)	$N \times 2,35 + 12$	$N \times 2,35 + 16$
WEIGHT CALCULATION (kg)	$N \times 0,4 + 10$	$N \times 0,4 + 14$

CONNECTIONS TYPE					
Soldering	Threaded M	Threaded F	Grooved	Rotalock	Flanges
S22	C48	F48	V50	R32	CF66
S28	IC48	F60	V65	R44	
S35	C60	IF48		R58	
S42	IC60	IF60			
S54	G48				
S60	G60				
	G70				
Standard Connections: F1 S35 F2 S54 W1-W2 C60					
FOR SPECIAL CONNECTIONS SEE PAGE 34 AND 35					

Weight of connections not included

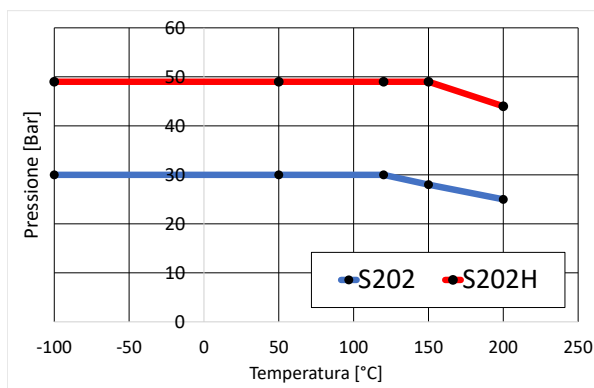

N Number of plates

LETTER TO IDENTIFY CONNECTIONS TYPE

- S** Soldering Connections
- C** Conical Male Gas Threaded Connections
- G** Cylindric Male Gas Threaded Connections
- F** Female Gas Threaded Connections
- V-BV** Grooved System for Standard Flexible Coupling
- R** Rotalock Connections Male

EXCHANGE PLATE MATERIAL Stainless Steel 316L
 BRAZING MATERIAL Copper (Cu)

S404-S404M SINGLE CIRCUIT

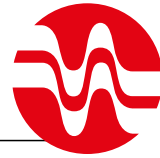

ONDA

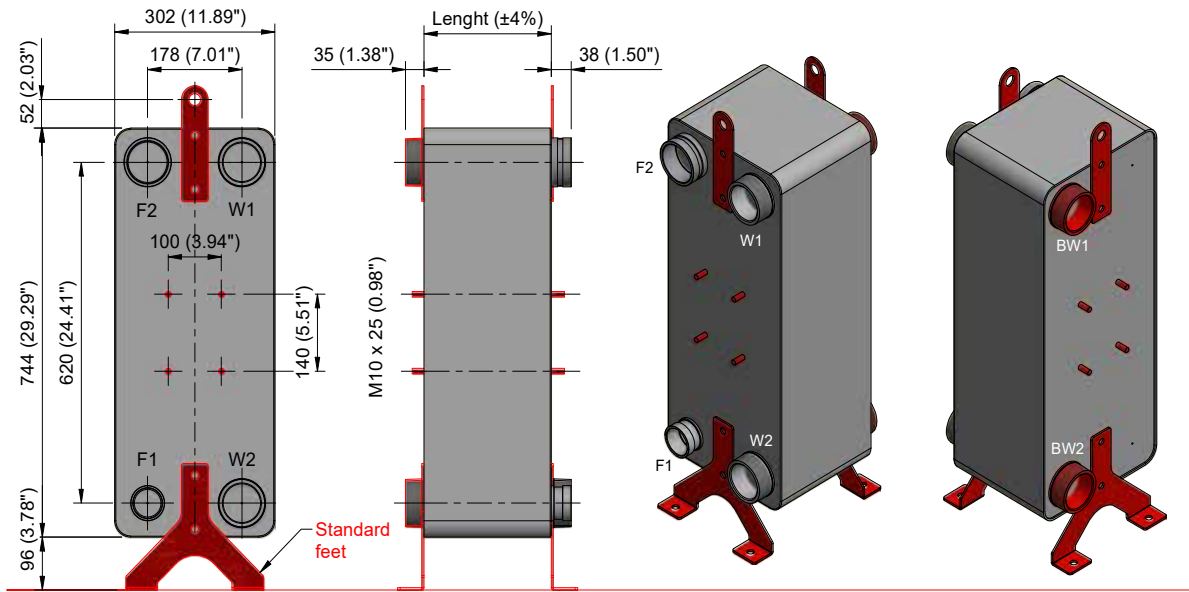

Optional: stud bolts and mounting feet (mod. S424 available)

F1 INLET Refrigerant W1-BW1 INLET Secondary Fluid
 F2 OUTLET Refrigerant W2-BW2 OUTLET Secondary Fluid

SPECIFICATIONS	S404
PS (bar)	30
TEMPERATURE RANGE (°C)	-100°C to +120°C
MAXIMUM CONNECTIONS AVAILABLE (mm)	84,7
MAXIMUM FLOW RATE (m3/h)	76,2
VOLUME / CHANNEL (liters)	0,56
DIMENSIONS (mm)	305 x 745
LENGHT CALCULATION (mm)	$N \times 2,85 + 20$
WEIGHT CALCULATION (kg)	$N \times 0,67 + 35$

CONNECTIONS TYPE					
Soldering	Threaded M	Threaded F	Grooved	Rotalock	Flanges
S54	C76	F22	V76	R58	NF80*
S64	IC73	F27	V80		CF80
S76	C90	IF22	V90		CF65
S90	IC90	IF27			
	G76	IF32			
	G90				
Standard Connections: F1 S54 F2 S76 W1-W2 G90					
FOR SPECIAL CONNECTIONS SEE PAGE 34 AND 35					

Weight of connections not included

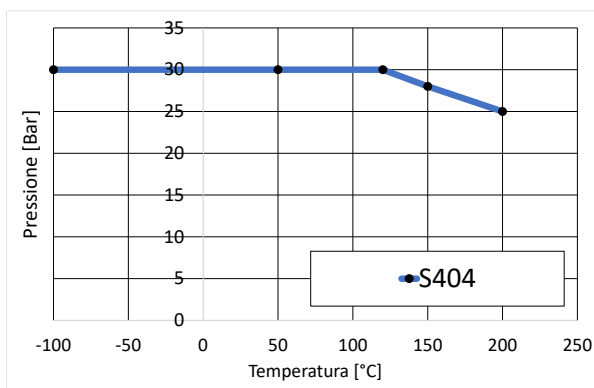

N Number of plates * ONLY IN W1/W2

LETTER TO IDENTIFY CONNECTIONS TYPE

- S** Soldering Connections
- C** Conical Male Gas Threaded Connections
- G** Cylindric Male Gas Threaded Connections
- F** Female Gas Threaded Connections
- V-BV** Grooved System for Standard Flexible Coupling
- R** Rotalock Connections Male

EXCHANGE PLATE MATERIAL Stainless Steel 316L
 BRAZING MATERIAL Copper (Cu)

S606 - S606M SINGLE CIRCUIT

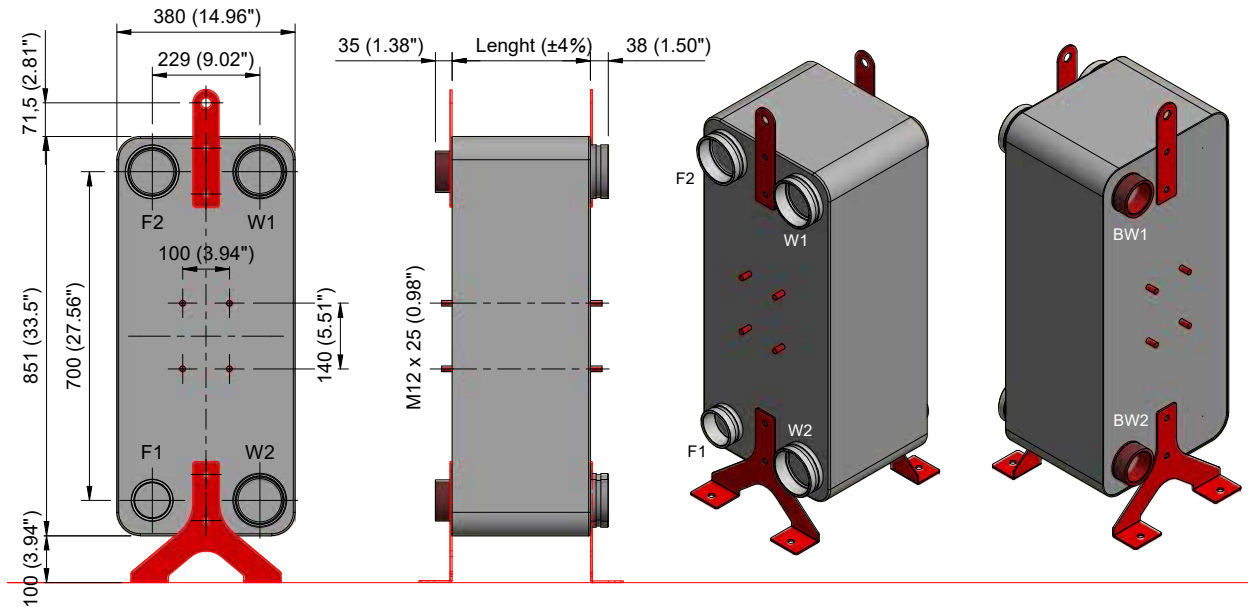

Optional: stud bolts and mounting feet

F1 INLET Refrigerant W1-BW1 INLET Secondary Fluid
 F2 OUTLET Refrigerant W2-BW2 OUTLET Secondary Fluid

SPECIFICATIONS	S606
PS (bar)	20
TEMPERATURE RANGE (°C)	-100°C to +120°C
MAXIMUM CONNECTIONS AVAILABLE (mm)	110,1
MAXIMUM FLOW RATE (m3/h)	76,2
VOLUME / CHANNEL (liters)	0,79
DIMENSIONS (mm)	385 x 850
LENGHT CALCULATION (mm)	$N \times 2,85 + 19$
WEIGHT CALCULATION (kg)	$N \times 0,86 + 50$

CONNECTIONS TYPE				
Soldering	Threaded M	Threaded F	Grooved	Flanges
S54	C76	F22	V73	NF100
S64	IC73	F27	V80	NF80
IS65	C90	IF22	V90	CF80
S76	IC90	IF27	V100	CF100
IS80	C100	IF32		
S90	IC100			
IS92	G76			
S100	G90			
	G100			
Standard Connections: F1 S76 F2 S100 W1-W2 V100				
FOR SPECIAL CONNECTIONS SEE PAGE 34 AND 35				

Weight of connections not included

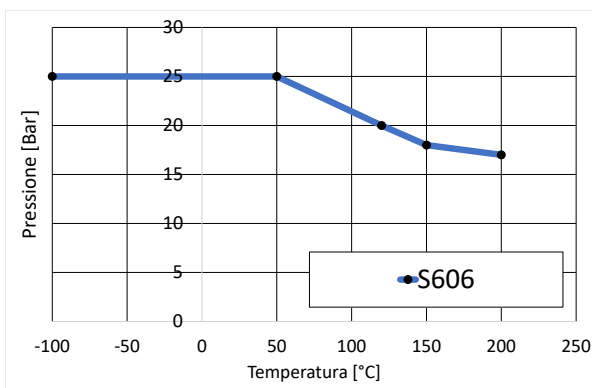

N Number of plates

LETTER TO IDENTIFY CONNECTIONS TYPE

- S** Soldering Connections
- C** Conical Male Gas Threaded Connections
- G** Cylindric Male Gas Threaded Connections
- F** Female Gas Threaded Connections
- V-BV** Grooved System for Standard Flexible Coupling
- R** Rotolock Connections Male

EXCHANGE PLATE MATERIAL Stainless Steel 316L
 BRAZING MATERIAL Copper (Cu)

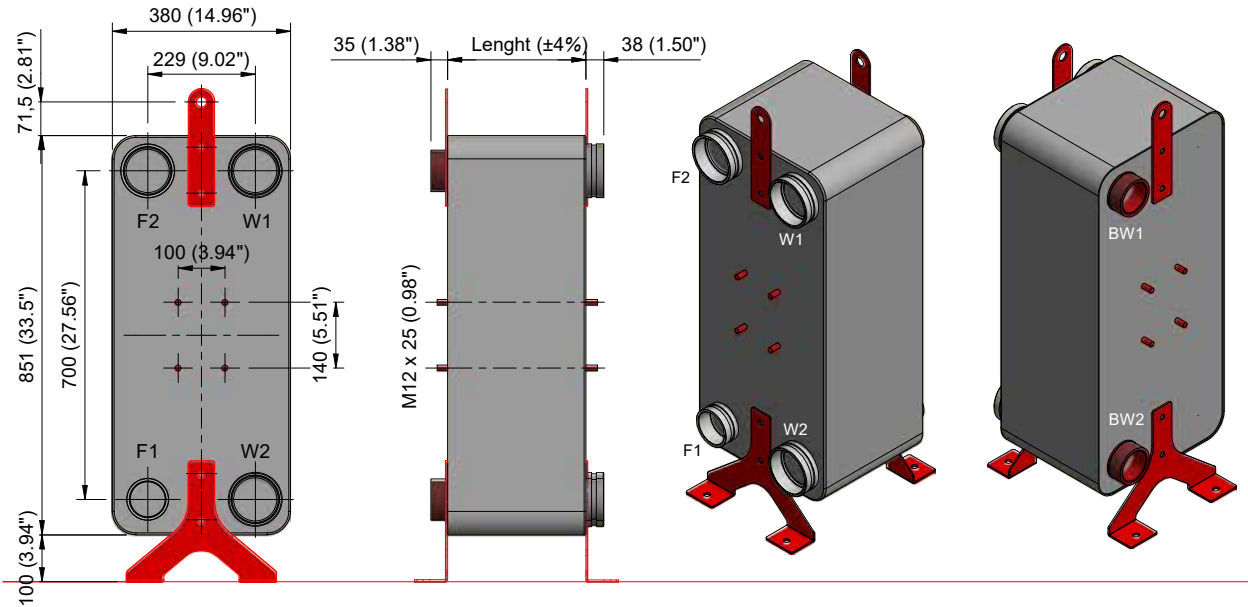

Optional: stud bolts and mounting feet

F1 INLET Refrigerant W1-BW1 INLET Secondary Fluid
 F2 OUTLET Refrigerant W2-BW2 OUTLET Secondary Fluid

SPECIFICATIONS	S608
PS (bar)	20*
TEMPERATURE RANGE (°C)	-100°C to +100°C
MAXIMUM CONNECTIONS AVAILABLE (mm)	100
MAXIMUM FLOW RATE (m3/h)	131,6
VOLUME / CHANNEL (liters)	0,63
DIMENSIONS (mm)	385 x 850
LENGHT CALCULATION (mm)	$N \times 2,35 + 19$
WEIGHT CALCULATION (kg)	$N \times 0,86 + 50$

*Available only for liquid to liquid group 2 fluid

Weight of connections not included

CONNECTIONS TYPE				
Soldering	Threaded M	Threaded F	Grooved	Flanges
S54	C76	F22	V73	NF100
S64	IC73	F27	V80	NF80
IS65	C90	IF22	V90	CF80
S76	IC90	IF27	V100	CF100
IS80	C100	IF32		
S90	IC100			
IS92	G76			
S100	G90			
	G100			
Standard Connections: F1 = F2 = W1 = W2 = V100				
FOR SPECIAL CONNECTIONS SEE PAGE 34 AND 35				

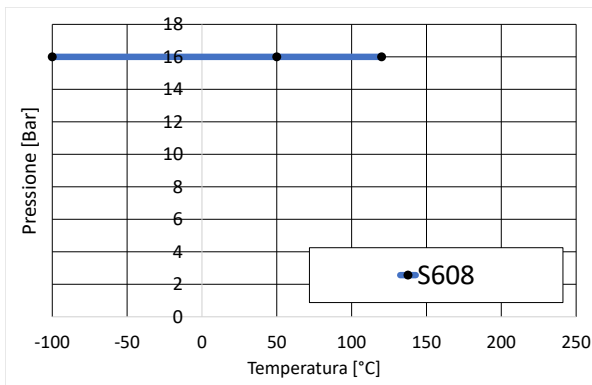

N Number of plates

LETTER TO IDENTIFY CONNECTIONS TYPE

- S** Soldering Connections
- C** Conical Male Gas Threaded Connections
- G** Cylindric Male Gas Threaded Connections
- F** Female Gas Threaded Connections
- V-BV** Grooved System for Standard Flexible Coupling
- R** Rotalock Connections Male

EXCHANGE PLATE MATERIAL Stainless Steel 316L
 BRAZING MATERIAL Copper (Cu)

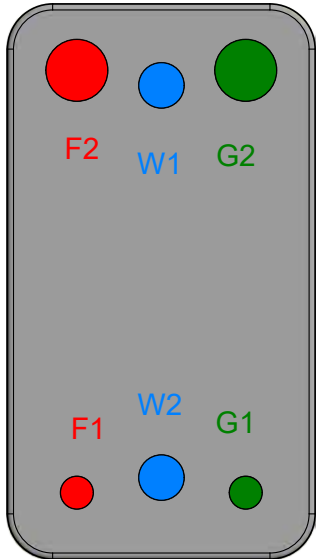

 = Circuit F

 = Circuit W

 = Circuit G

S222

p. 28

S424

p. 29

S727

p. 30

DUAL
CIRCUIT

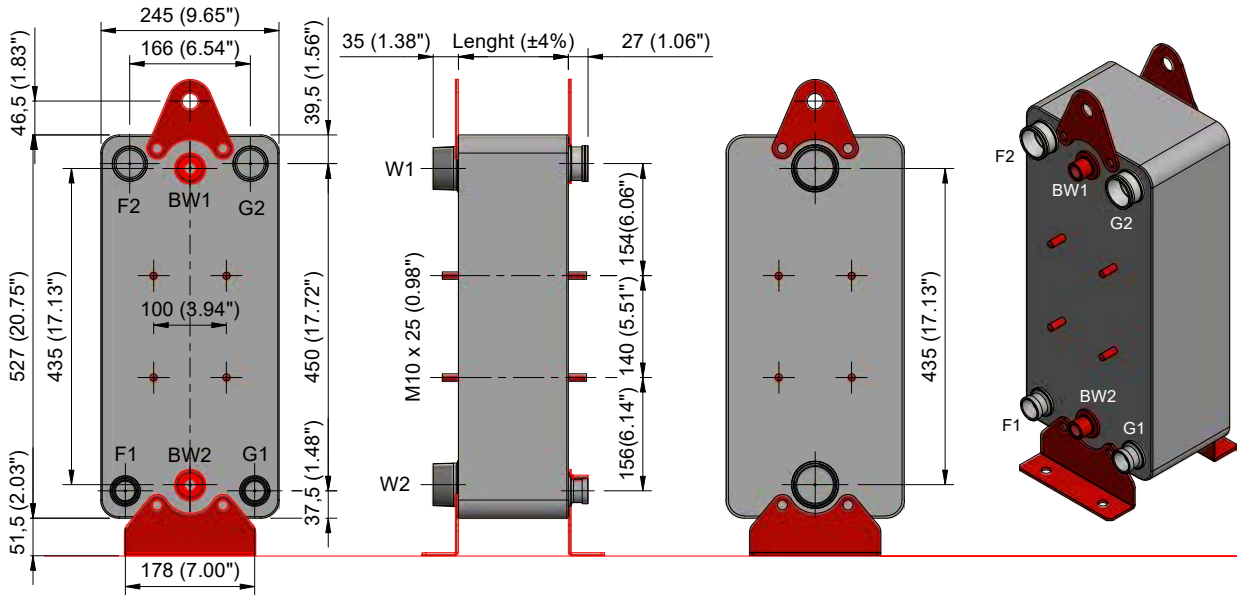

Optional: stud bolts and mounting feet

- | | | | |
|-----------|------------------------|-----------|-----------------------|
| F1 INLET | Refrigerant Circuit 1 | F2 OUTLET | Refrigerant Circuit 1 |
| G1 INLET | Refrigerant Circuit 2 | G2 OUTLET | Refrigerant Circuit 2 |
| W1 INLET | Secondary Fluid | W2 OUTLET | Secondary Fluid |
| BW1 - BW2 | Connections for Sensor | | |

SPECIFICATIONS	S222	S222H	CONNECTIONS TYPE					
			Soldering	Threaded M	Threaded F	Grooved	Rotalock	Flanges
PS (bar)	30	49	S22	C48	F22	V50	R32	
TEMPERATURE RANGE (°C)	-100°C to +120°C	-100°C to +150°C	S28	IC48	F27	V65	R44	CF66
MAXIMUM CONNECTIONS AVAILABLE (mm)	57	57	IS29	C60	IF22		R58	
MAXIMUM FLOW RATE (m3/h)	31,5	31,5	S35	IC60	IF27			
VOLUME / CHANNEL (liters)	0,269	0,269	S42	G48				
DIMENSIONS (mm)	245 x 527	245 x 527	IS41	G60				
LENGHT CALCULATION (mm)	$N \times 2,35 + 15$	$N \times 2,35 + 19$	S50					
WEIGHT CALCULATION (kg)	$N \times 0,4 + 10$	$N \times 0,4 + 18$	Standard Connections F1-G1 S28 F2-G2 S42 W1-W2 G60 BW1-BW2 F22					
FOR SPECIAL CONNECTIONS SEE PAGE 34 AND 35								

Weight of connections not included

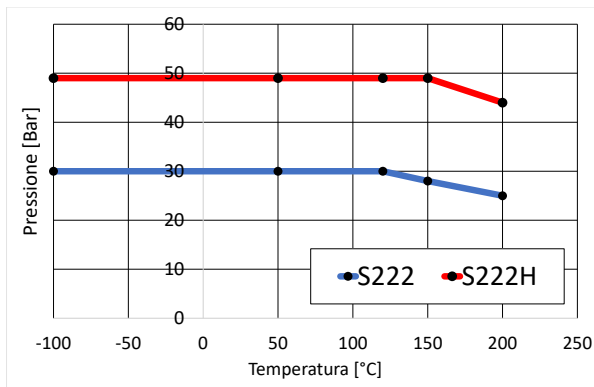

N Number of plates

LETTER TO IDENTIFY CONNECTIONS TYPE

- S** Soldering Connections
- C** Conical Male Gas Threaded Connections
- G** Cylindric Male Gas Threaded Connections
- F** Female Gas Threaded Connections
- V - BV** Grooved System for Standard Flexible Coupling
- R** Rotalock Connections Male

EXCHANGE PLATE MATERIAL Stainless Steel 316L

BRAZING MATERIAL Copper (Cu)

Criss-Cross Flow Pattern Available on Request

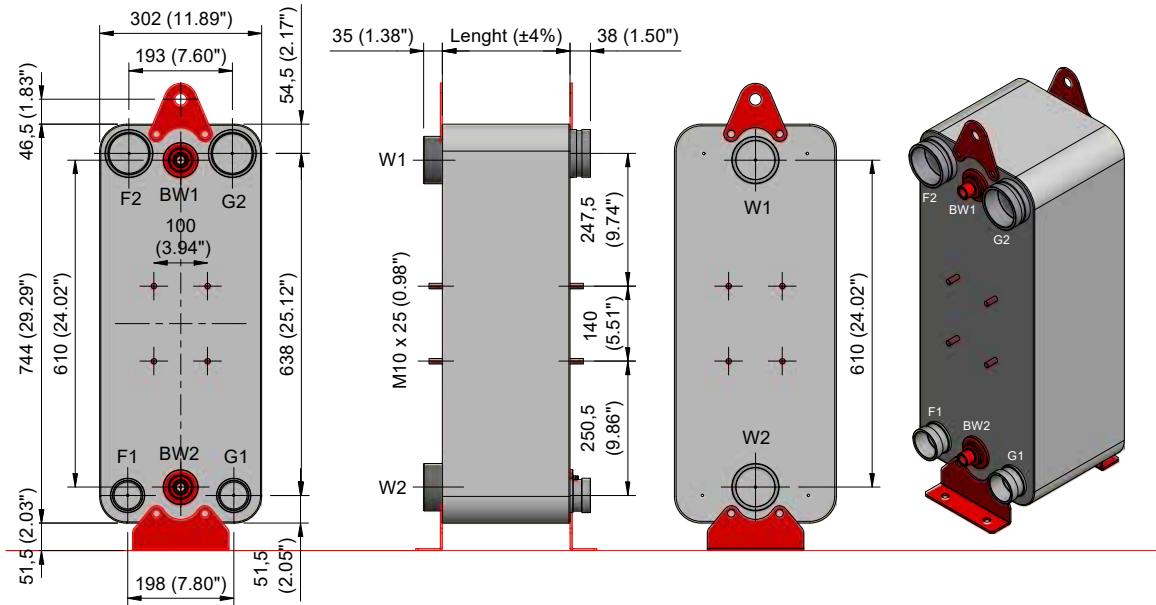

Optional: stud bolts and mounting feet

- | | | | |
|-----------|------------------------|-----------|-----------------------|
| F1 INLET | Refrigerant Circuit 1 | F2 OUTLET | Refrigerant Circuit 1 |
| G1 INLET | Refrigerant Circuit 2 | G2 OUTLET | Refrigerant Circuit 2 |
| W1 INLET | Secondary Fluid | W2 OUTLET | Secondary Fluid |
| BW1 - BW2 | Connections for Sensor | | |

SPECIFICATIONS	S424	S424H	CONNECTIONS TYPE							
			Soldering	Threaded M	Threaded F	Grooved	Rotalock	Flanges		
PS (bar)	30	49								
TEMPERATURE RANGE (°C)	-100°C to +120°C	-100°C to +150°C	S35	C76	F22	V73	R44	NF80		
MAXIMUM CONNECTIONS AVAILABLE (mm)	84,7	84,7	S42	IC73	F27	V80	R58	NF65		
MAXIMUM FLOW RATE (m3/h)	76,2	76,2	S54	C90	IF22	V90		CF65		
VOLUME / CHANNEL (liters)	0,484	0,484	S64	IC90	IF27					
DIMENSIONS (mm)	305 x 745	305 x 745	IS65	G76						CF80
LENGHT CALCULATION (mm)	$N \times 2,85 + 20$	$N \times 2,85 + 24$	S76	G90						
WEIGHT CALCULATION (kg)	$N \times 0,67 + 33$	$N \times 0,67 + 38$	IS80							
			S90							
			Standard Connections: F1-G1 S54 F2-G2 S76 W1-W2 C90 BW1-BW2 F22							
			FOR SPECIAL CONNECTIONS SEE PAGE 34 AND 35							

Weight of connections not included

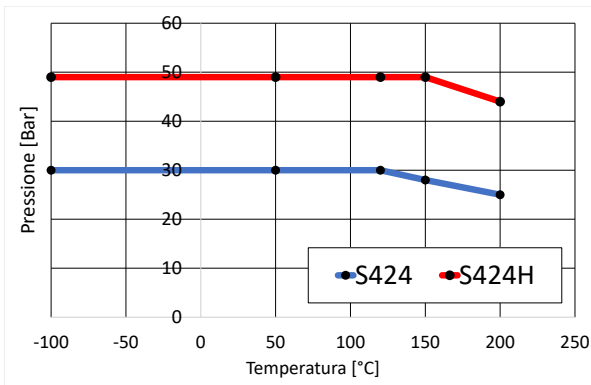

- N** Number of plates
- LETTER TO IDENTIFY CONNECTIONS TYPE**
- S** Soldering Connections
 - C** Conical Male Gas Threaded Connections
 - G** Cylindric Male Gas Threaded Connections
 - F** Female Gas Threaded Connections
 - V - BV** Grooved System for Standard Flexible Coupling
 - R** Rotalock Connections Male
- EXCHANGE PLATE MATERIAL Stainless Steel 316L
- BRAZING MATERIAL Copper (Cu)
- Criss-Cross Flow Pattern Available on Request

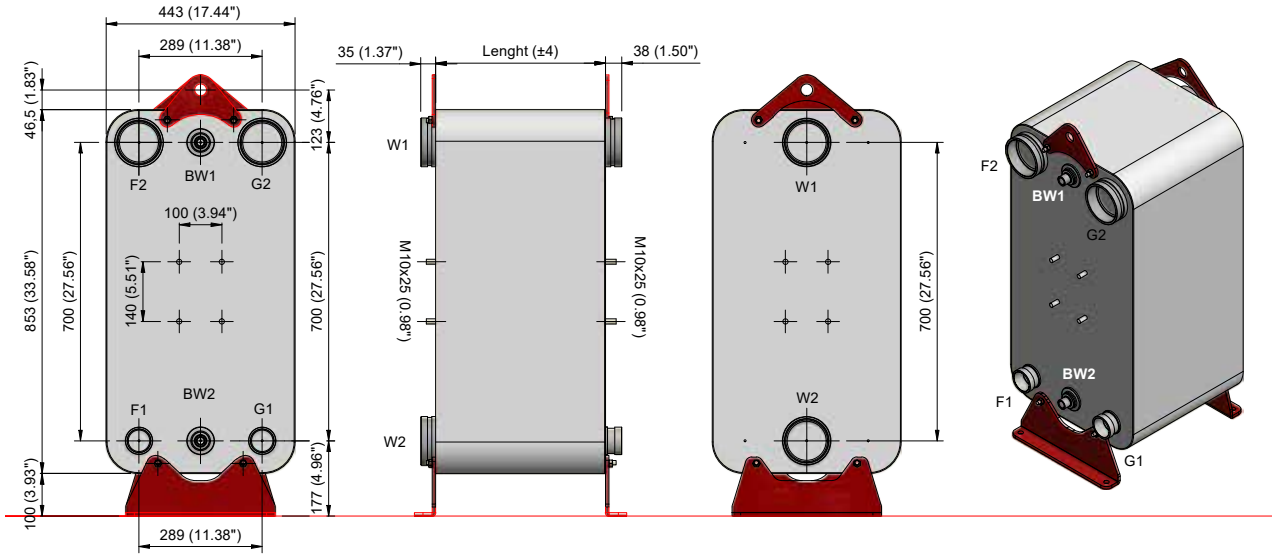

Optional: stud bolts and mounting feet

- F1 INLET Refrigerant Circuit 1
- G1 INLET Refrigerant Circuit 2
- W1 INLET Secondary Fluid
- BW1 - BW2 Connections for Sensor
- F2 OUTLET Refrigerant Circuit 1
- G2 OUTLET Refrigerant Circuit 2
- W2 OUTLET Secondary Fluid

SPECIFICATIONS	S727
PS (bar)	16
TEMPERATURE RANGE (°C)	-100°C to +120°C
MAXIMUM CONNECTIONS AVAILABLE (mm)	125
MAXIMUM FLOW RATE (m3/h)	131,6
VOLUME / CHANNEL (liters)	0,55
DIMENSIONS (mm)	440 x 850
LENGHT CALCULATION (mm)	$N \times 2,40 + 12$
WEIGHT CALCULATION (kg)	$N \times 1,26 + 60$

CONNECTIONS TYPE					
Soldering	Threaded M	Threaded F	Grooved	Rotalock	Flanges
S54	C60	F22	V80	R44	DN65
>	>	>	V90	R58	DN80
IS108	C90	F60	V100		DN100
					DN125
Standard Connections F1-G1 S42-A F2-G2 S100 W1-W2 DN100 BW1-BW2 F22 FOR SPECIAL CONNECTIONS SEE PAGE 34 AND 35					

Weight of connections not included

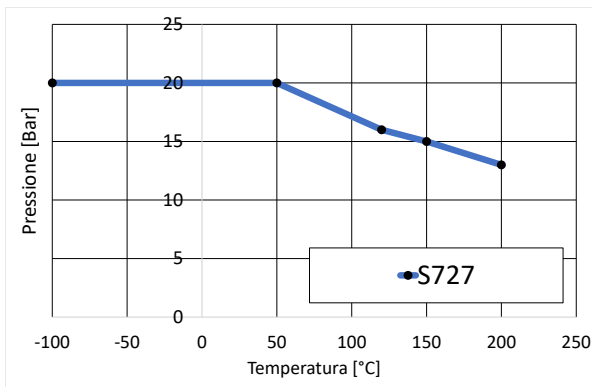

N Number of plates

LETTER TO IDENTIFY CONNECTIONS TYPE

- S** Soldering Connections
- C** Conical Male Gas Threaded Connections
- G** Cylindric Male Gas Threaded Connections
- F** Female Gas Threaded Connections
- V - BV** Grooved System for Standard Flexible Coupling
- R** Rotalock Connections Male

EXCHANGE PLATE MATERIAL Stainless Steel 316L

BRAZING MATERIAL Copper (Cu)

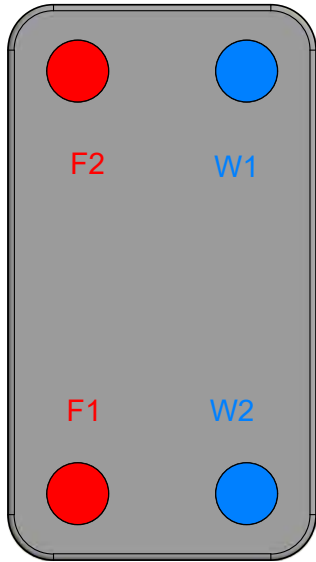

 = Circuit F

 = Circuit W

S16L

p. 32

S101L

p. 33

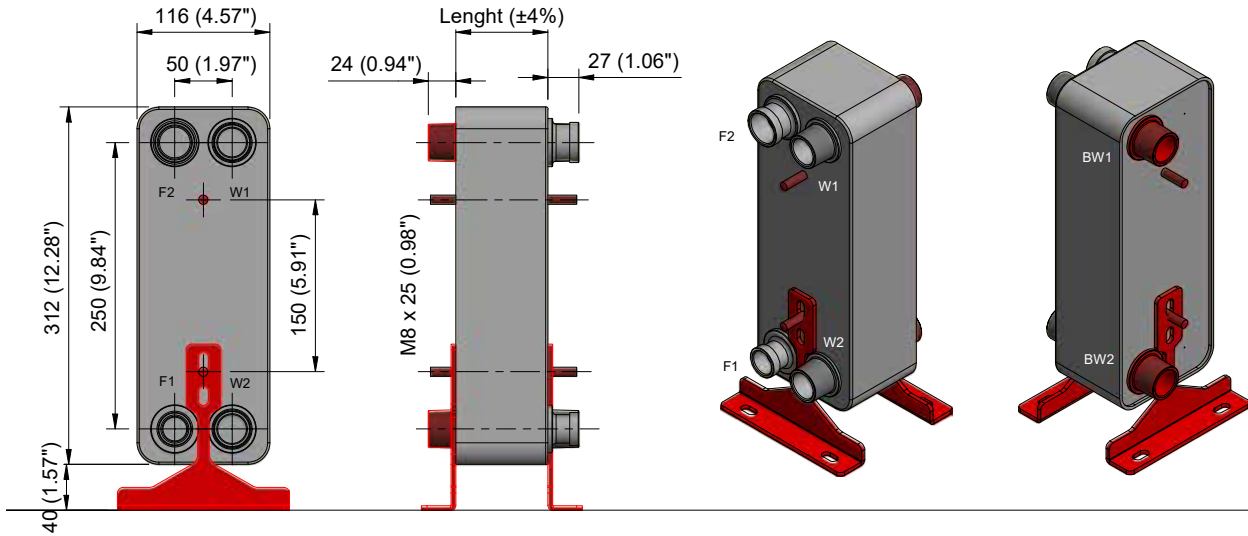

Optional: stud bolts and mounting feet

F1 INLET Refrigerant W1-BW1 INLET Secondary Fluid
 F2 OUTLET Refrigerant W2-BW2 OUTLET Secondary Fluid

SPECIFICATIONS	S16L	S16LH
PS (bar)	30	45
TEMPERATURE RANGE (°C)	-100°C to +120°C	-100°C to +120°C
MAXIMUM CONNECTIONS AVAILABLE (mm)	34	34
MAXIMUM FLOW RATE (m3/h)	9,7	9,7
VOLUME / CHANNEL (liters)	0,08	0,08
DIMENSIONS (mm)	116 x 312	116 x 312
LENGHT CALCULATION (mm)	N x 2,3 + 12	N x 2,3 + 16
WEIGHT CALCULATION (kg)	N x 0,1 + 1,5	N x 0,1 + 4

CONNECTIONS TYPE				
Soldering	Threaded M	Threaded F	Grooved	Rotalock
S6	C22	F22	V32	R19
S8	IC22	F27	BV32	R25
S12	C27	F32	V40	R32
S14	IC27	IF22	BV40	
S16	C32	IF27		
S18	IC32	IF32		
S19	G22			
S22	G27			
S28	G32			
S35				
Standard Connections: F1 S22 F2 S28 W1-W2 C32				
FOR SPECIAL CONNECTIONS SEE PAGE 34 AND 35				

Weight of connections not included

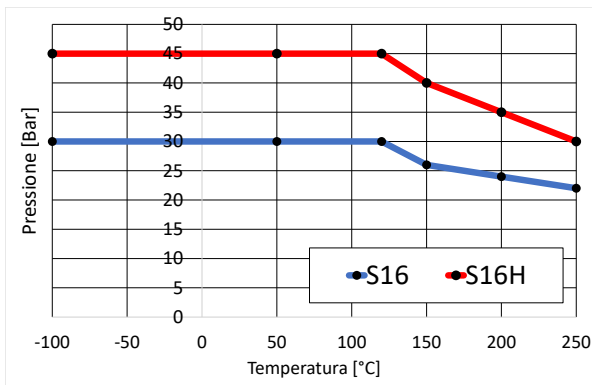

N Number of plates

LETTER TO IDENTIFY CONNECTIONS TYPE

- S** Soldering Connections
- C** Conical Male Gas Threaded Connections
- G** Cylindric Male Gas Threaded Connections
- F** Female Gas Threaded Connections
- V-BV** Grooved System for Standard Flexible Coupling
- R** Rotalock Connections Male

EXCHANGE PLATE MATERIAL Stainless Steel 316L
 BRAZING MATERIAL Copper (Cu)

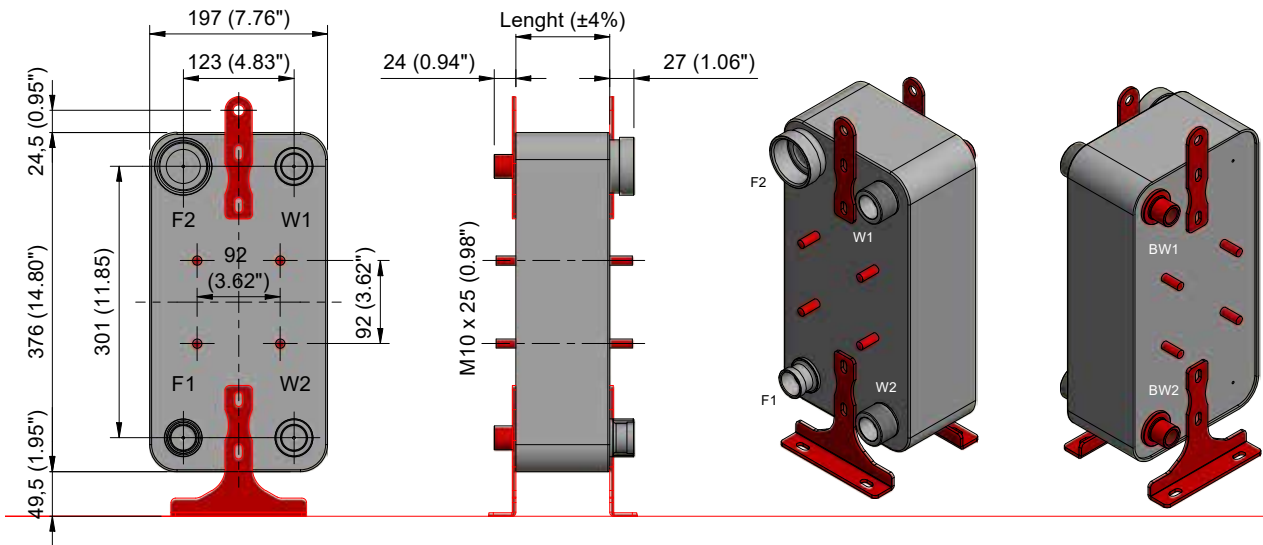

Optional: stud bolts and mounting feet

F1 INLET Refrigerant W1-BW1 INLET Secondary Fluid
 F2 OUTLET Refrigerant W2-BW2 OUTLET Secondary Fluid

SPECIFICATIONS	S101L	S101LH
PS (bar)	30	45
TEMPERATURE RANGE (°C)	-100°C to +120°C	-100°C to +120°C
MAXIMUM CONNECTIONS AVAILABLE (mm)	42	42
MAXIMUM FLOW RATE (m3/h)	15,9	15,9
VOLUME / CHANNEL (liters)	0,130	0,130
DIMENSIONS (mm)	197 x 376	197 x 376
LENGHT CALCULATION (mm)	N x 2,20 + 14	N x 2,20 + 14
WEIGHT CALCULATION (kg)	N x 0,26 + 9	N x 0,26 + 9
SAME "H" DESIGN		

Weight of connections not included

CONNECTIONS TYPE				
Soldering	Threaded M	Threaded F	Grooved	Rotalock
S22	C32	F27	V32	R32
S28	C42	F32	V40	R44
S35	G32	F42		R58
S42	G42	IF27		
S50	IC32	IF32		
	IC42	IF42		
Standard Connections: F1 S35 F2 S50 W1-W2 C42				
FOR SPECIAL CONNECTIONS SEE PAGE 34 AND 35				

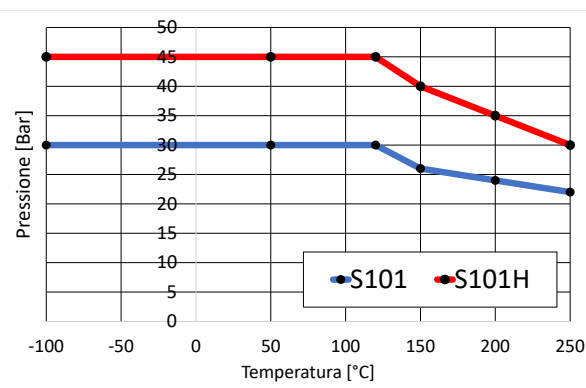

N Number of plates

LETTER TO IDENTIFY CONNECTIONS TYPE

- S** Soldering Connections
- C** Conical Male Gas Threaded Connections
- G** Cylindric Male Gas Threaded Connections
- F** Female Gas Threaded Connections
- V-BV** Grooved System for Standard Flexible Coupling
- R** Rotalock Connections Male

EXCHANGE PLATE MATERIAL Stainless Steel 316L
 BRAZING MATERIAL Copper (Cu)

ALL POSSIBLE CONNECTIONS
FOR THESE CONNECTIONS CONTACT TECHNICAL DEPT

S06 / S07 / S09 / S22			
Soldering	Threaded M	Threaded F	Rotalock R
S6/20	C22/20	F22/20	R19/20
S8/20	C27/20	IF6/20	R25/20
S9/20	IC22/20	IF8/20	
S10/20	IC27/20	IF22/20	
S12/20	G22/20	IF26/20	
S14/20	G27/20		
S16/20			
S18/20			
S19/20			
S20/20			

S16				
Soldering	Threaded M	Threaded F	Rotalock R	Grooved V
S6/27	C22/27	F22/27	R19/27	V32/27
S8/27	C27/27	F27/27	R25/27	V40/27
S9/27	C32/27	F32/27	R32/27	BV32
S10/27	IC22/27	IF6/27		BV40
S12/27	IC27/27	IF8/27		
S14/27	IC32/27	IF22/27		
S16/27	G22/27	IF27/27		
S18/27	G27/27	IF32/27		
S19/27	G32/27			
S22/27				
S28/27				
S35/27				

S12 / S62 / S82 / S82M S87 / S93				
Soldering	Threaded M	Threaded F	Rotalock R	Grooved V
S6/27	C22/27	F22/27	R19/27	V32/27
S8/27	C27/27	F27/27	R25/27	V40/27
S9/27	C32/27	F32/27	R27/93	BV32
S10/27	C42/27	F42/27	R32/27	BV40
S12/27	IC22/27	IF6/27	R44/27	
S14/27	IC27/27	IF8/27		
S16/27	IC32/27	IF22/27		
S18/27	IC42/27	IF27/27		
S19/27	G22/27	IF32/27		
S22/27	G27/27	IF42/27		
S28/27	G32/27			
S35/27	G42/27			

S101				
Soldering	Threaded M	Threaded F	Rotalock R	Grooved V
S6/27	C22/27	F22/27	R19/27	V32/27
S8/27	C27/27	F27/27	R25/27	V40/27
S9/27	C32/27	F32/27	R32/27	BV32
S10/27	C42/27	F42/27	R44/27	BV40
S12/27	IC22/27	IF6/27	R58/27	
S14/27	IC27/27	IF8/27		
S16/27	IC32/27	IF22/27		
S18/27	IC42/27	IF27/27		
S19/27	G22/27	IF32/27		
S22/27	G27/27	IF42/27		
S28/27	G32/27			
S35/27	G42/27			
IS41/27				
S42/27				
S50/27				

S182 / S182M / S202 / S202M / S222					
Soldering	Threaded M	Threaded F	Rotalock R	Grooved V	Flanges F
S6/38	C22/38	F22/38	R19/38	V32/38	CF66
S8/38	C27/38	F27/38	R25/38	V40/38	
S9/38	C32/38	F32/38	R32/38	V50/38	
S10/38	C42/38	F42/38	R44/38	V65/38	
S12/38	C48/38	F48/38	R58/38	BV32	
S14/38	C60/38	F60/38		BV40	
S16/38	IC22/38	IF6/38			
S18/38	IC27/38	IF8/38			
S19/38	IC32/38	IF22/38			
S22/38	IC42/38	IF27/38			
S28/38	IC48/38	IF32/38			
S35/38	IC60/38	IF42/38			
IS41/38	G22/38	IF48/38			
S42/38	G27/38	IF60/38			
S54/38	G32/38				
S60/38 *	G42/38				
	G48/38				
	G60/38				
	G70/38				

* NO S222

ALL POSSIBLE CONNECTIONS
FOR THESE CONNECTIONS CONTACT TECHNICAL DEPT

S404 / S424					
Soldering	Threaded M	Threaded F	Rotalock R	Grooved V	Flanges F
S6/38	C22/38	F22/38	R19/38	V32/38	CF65
S8/38	C27/38	F27/38	R25/38	V40/38	CF80
S9/38	C32/38	F32/38	R32/38	V50/38	NF65
S10/38	C42/38	F42/38	R44/38	V65/38	NF80
S12/38	C48/38	F48/38	R58/38	V80/38	IN65
S14/38	C60/38	F60/38		V80L	IN80
S16/38	C76/38	IF6/38		BV32	
S18/38	C90/38	IF8/38		BV40	
S19/38	IC22/38	IF22/38			
S22/38	IC27/38	IF27/38			
S28/38	IC32/38	IF32/38			
S35/38	IC42/38	IF42/38			
IS41/38	IC48/38	IF48/38			
S42/38	IC60/38	IF60/38			
S54/38	IC70/38	IF73/38			
S64/38	IC90/38				
IS66/38	G22/38				
S76/38	G27/38				
IS80/38	G32/38				
S90/38	G42/38				
IS92/38	G48/38				
	G60/38				
	G76/38				

S606 / S606M / S608 / S727					
Soldering	Threaded M	Threaded F	Rotalock R	Grooved V	Flanges F
S6/38	C22/38	F22/38	R19/38	V32/38	CF65
S8/38	C27/38	F27/38	R25/38	V40/38	CF80
S9/38	C32/38	F32/38	R32/38	V50/38	CF100
S10/38	C42/38	F42/38	R44/38	V65/38	NF65
S12/38	C48/38	F48/38	R58/38	V80/38	NF80
S14/38	C60/38	F60/38		V80L	NF100
S16/38	C76/38	IF6/38		V100/38	IN65
S18/38	C90/38	IF8/38		BV32	IN80
S19/38	IC22/38	IF22/38		BV40	IN100
S22/38	IC27/38	IF27/38			
S28/38	IC32/38	IF32/38			
S35/35	IC42/38	IF42/38			
IS41/38	IC48/38	IF48/38			
S42/38	IC60/38	IF60/38			
S54/38	IC60/38	IF73/38			
S64/38	IC70/38				
IS66/38	IC90/38				
S76/38	IC100/38				
IS80/38	G22/38				
S90/38	G27/38				
IS92/38	G32/38				
S100/38	G42/38				
IS102/38	G48/38				
IS108/38	G60/38				
	G76/38				
	G90/38				
	G100/38				

Connections height : 20, 27, 38 mm
Example S12/20, S28/27, G76/38

S = Soldering connections

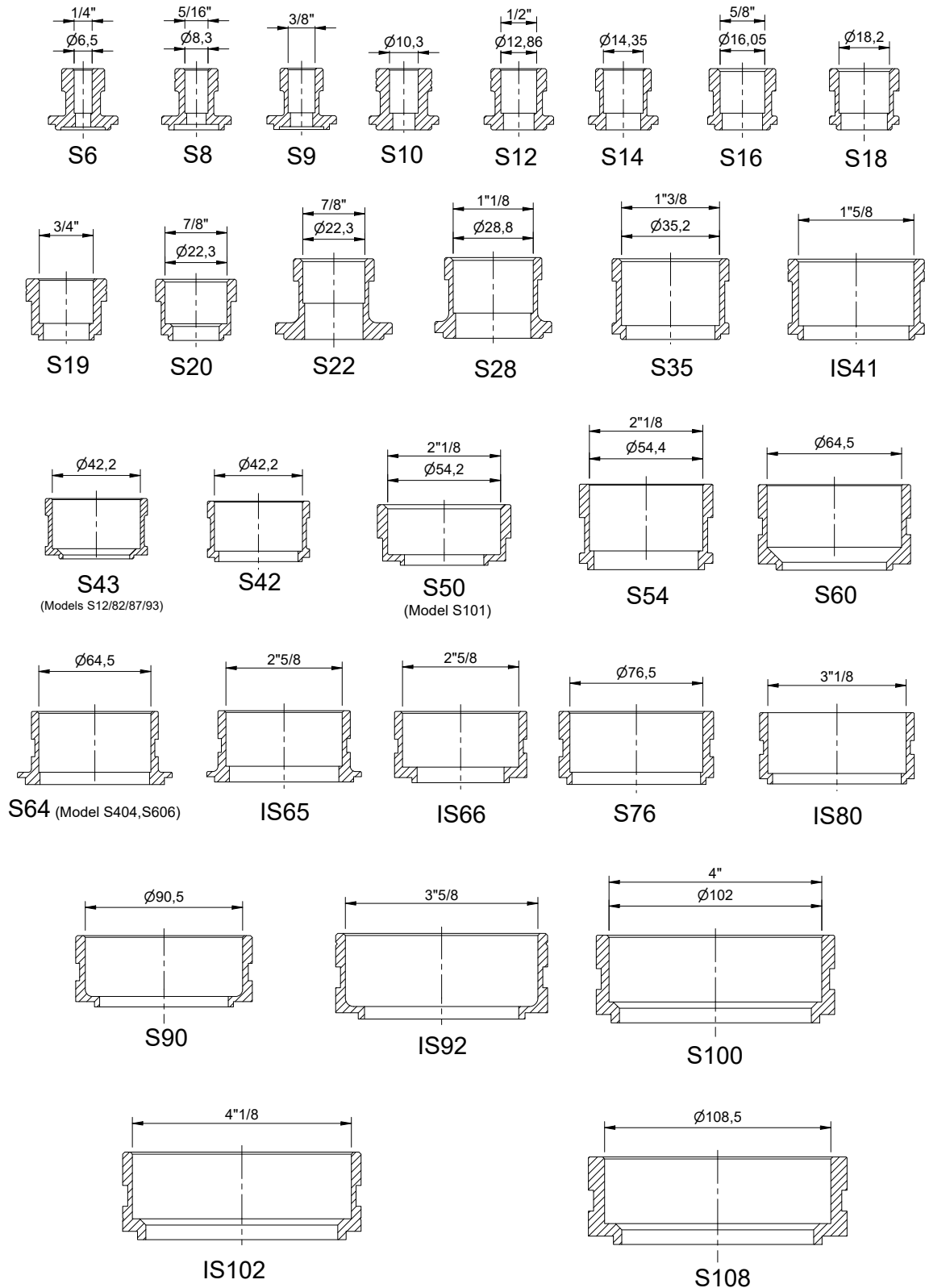

F= Gas thread connections female

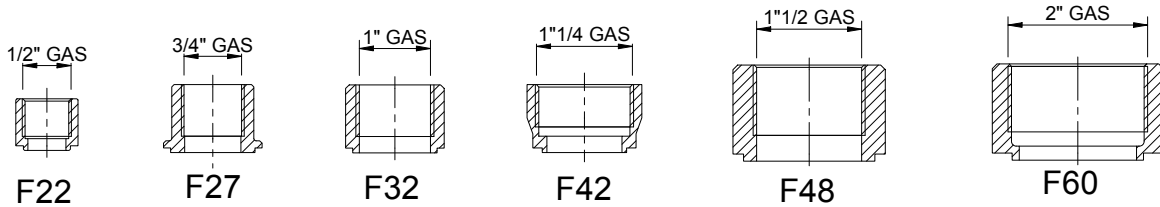

IF= NPT thread connections female

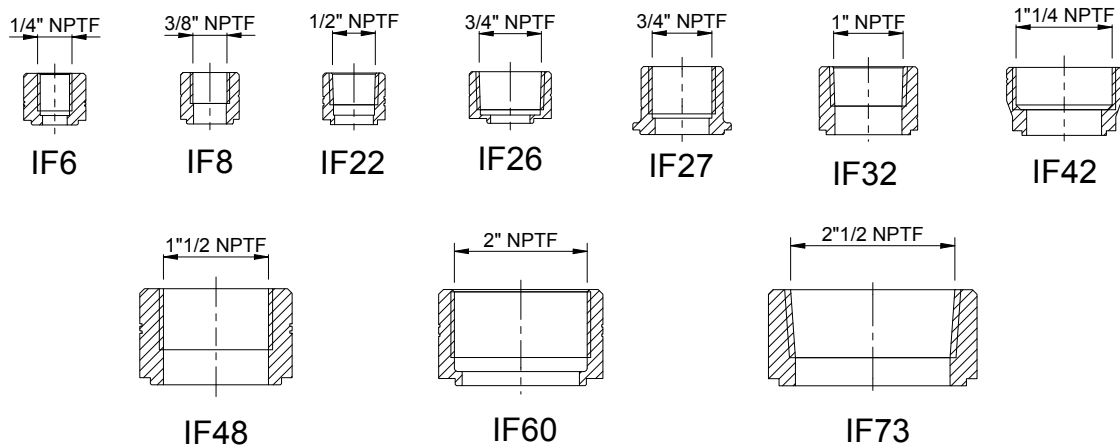

C= Gas thread connections male conical

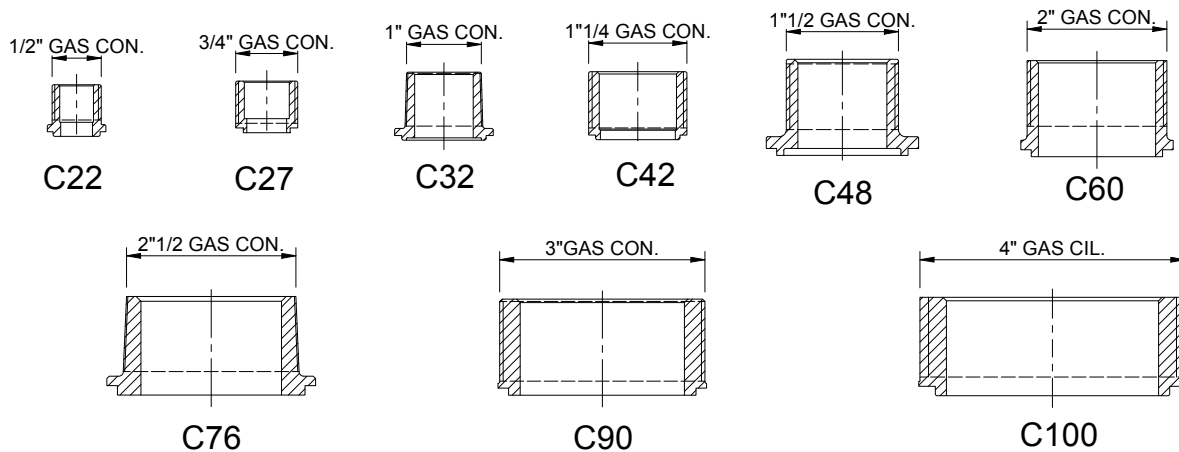

CONNECTIONS

IC= NPT thread connections male

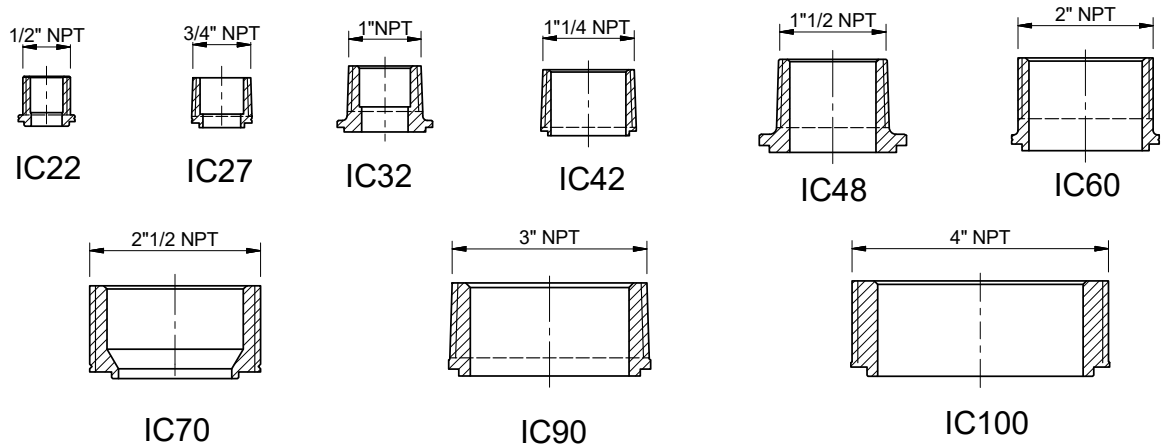

G= Gas thread connections male cylindrical

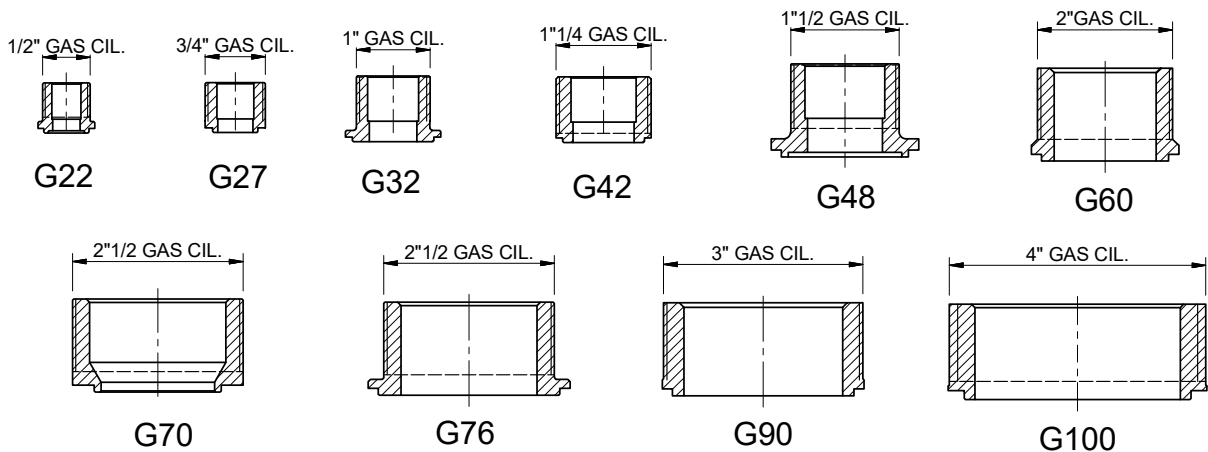

R= rotalock connections male

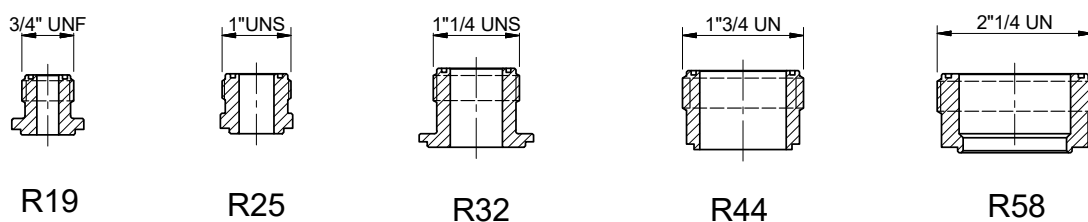

V-VB Grooved fittings

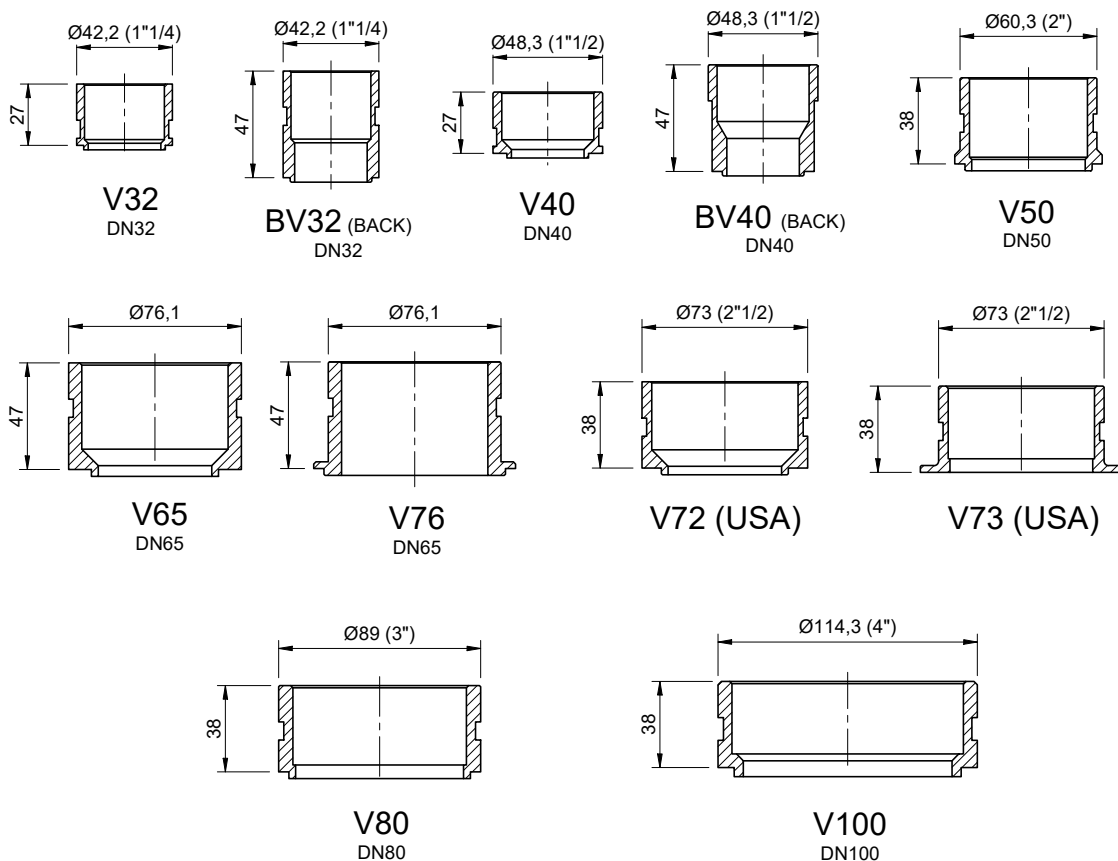

CF= Compact flanges special Onda (need counterflanges)

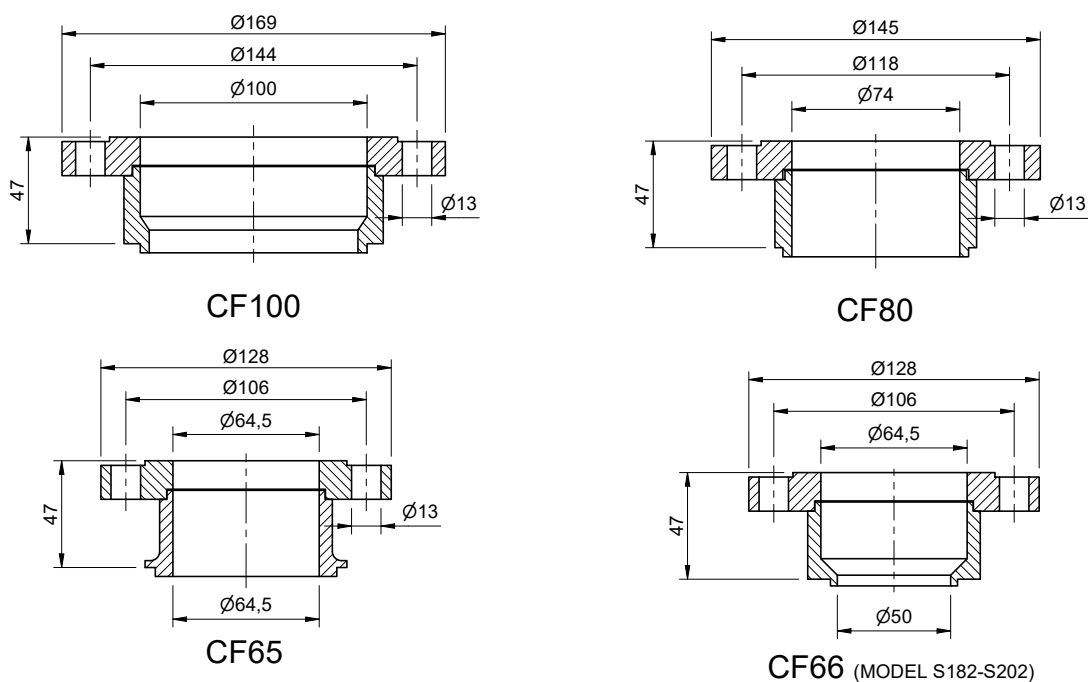

CONNECTIONS

NF= DIN flanges

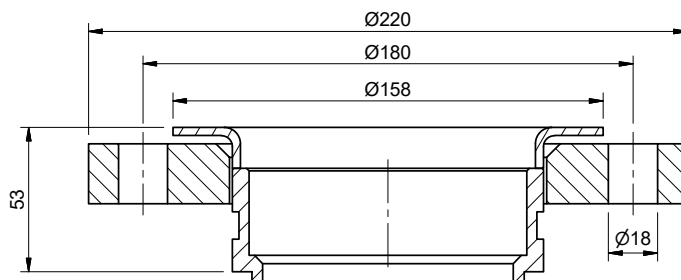

NF100 (DN100 - PN10/PN16)

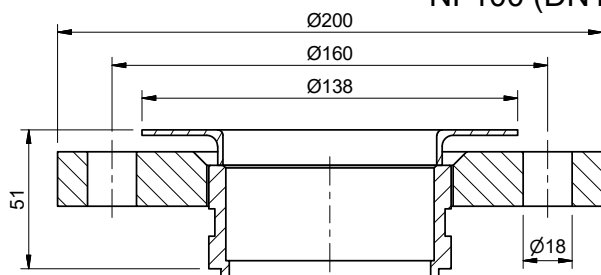

NF80 (DN80 - PN10/PN16)

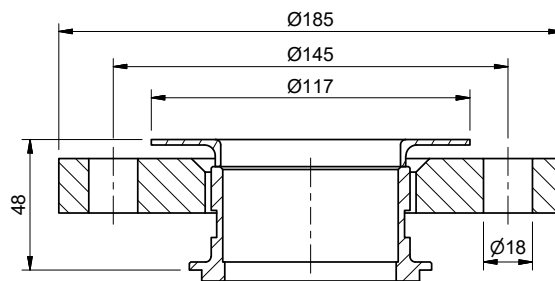

NF65 (DN65 - PN10/PN16)

IN= ANSI LAP JOINT FLANGES 300 Lb/sq.in.

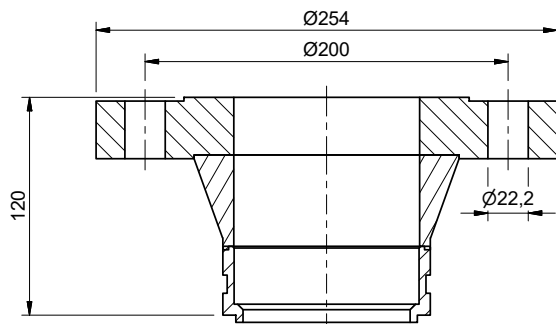

IN100 (4" - 300 Lb)

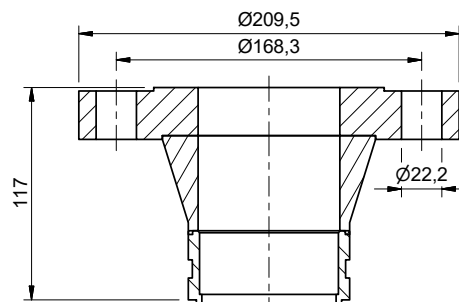

IN80 (3" - 300 Lb)

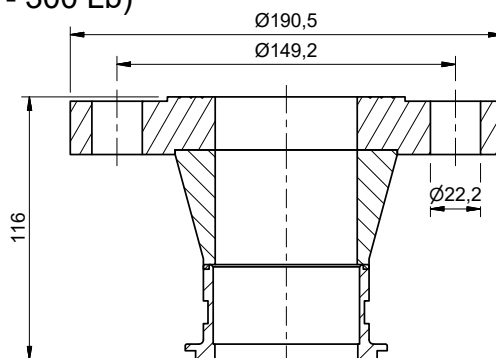

IN65 (2 1/2" - 300 Lb)

NB: the examples of configurations indicated are as condensers (for non 2-passes models).
In the case of evaporators the arrows are reversed.

Configuration: SINGLE CIRCUIT

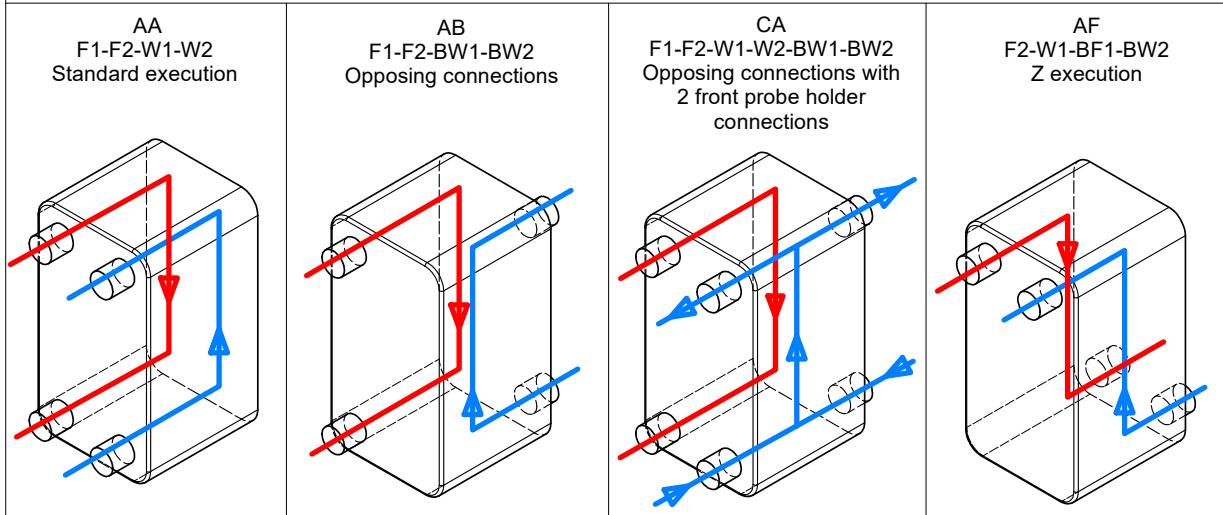

Configuration: SINGLE CIRCUIT (refrigerant on the right)

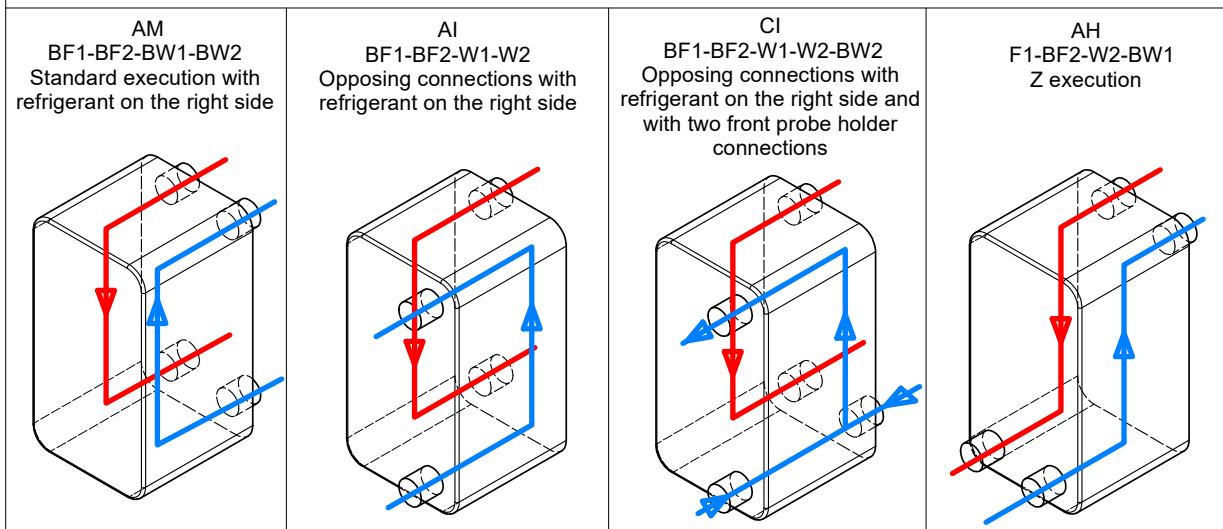

Configuration: SINGLE CIRCUIT 2 passes

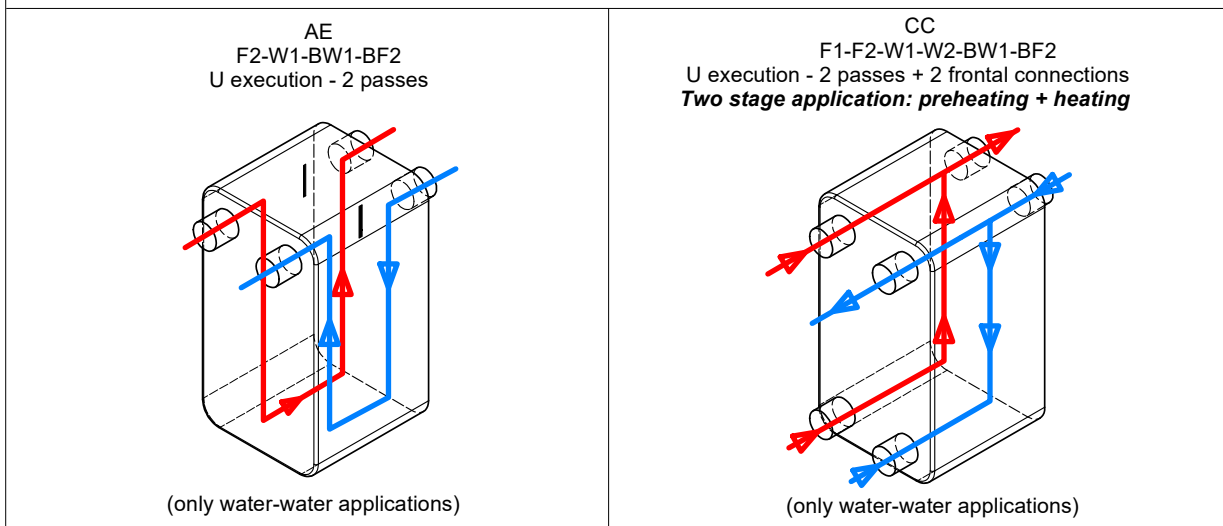

2 REFRIGERANT CIRCUITS AND 1 WATER CIRCUIT

(True) DUAL CIRCUITS

PA
F1-F2-G1-G2
W1-W2-BW1-BW2
True dual

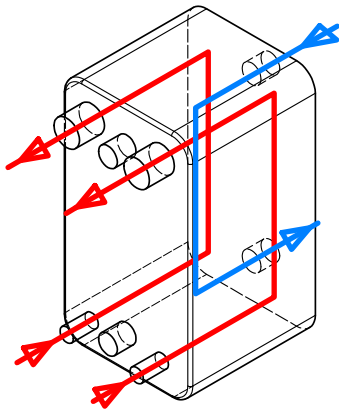

MA
F1-F2-G1-G2
BW1-BW2

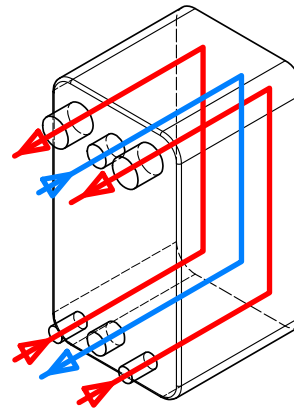

3 CIRCUITS

CB
F1-F2 / BF1-BF2 / W1-W2
3 circuits back to back

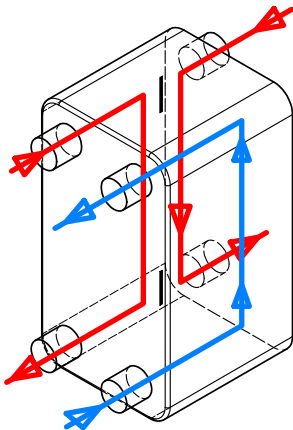

CF
F1-F2 / BF1-BF2 / W1-BW1
2 circuits in parallel on F side / 1 circuit in series W side

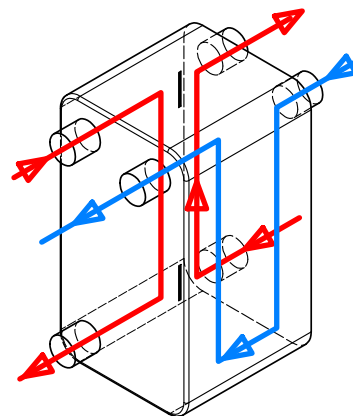

(only water-water applications)

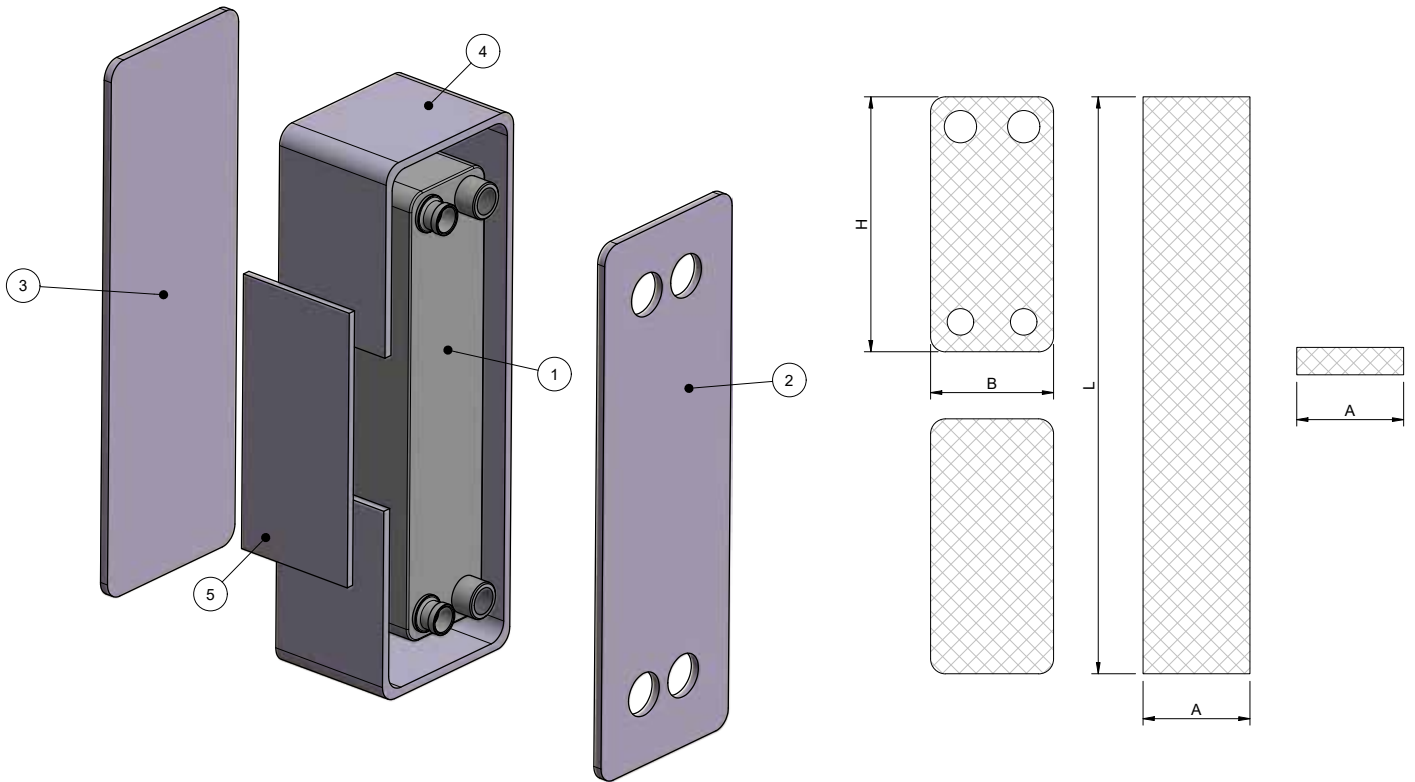

INSULATION HEAT EXCHANGER	
MATERIAL:	Reticulated polyethylene covered with black embossed film
THICKNESS:	Insulation KIT 5/16" thick (8 mm) à Item 06 EUR R PEN - Thickness 6+3 Insulation KIT 5/8" thick (19 mm) à Item 16 EUR R PEN - Thickness 16+3
OPERATING TEMPERATURE RANGE:	from -45°C to +110°C

INSULATION HEAT EXCHANGER	
1	BRAZED PLATE HEAT EXCHANGER
2	FRONT ADHESIVE PANEL
3	REAR ADHESIVE PANEL
4	BORDER ADHESIVE PANEL
5	COVER ADHESIVE STRIPE

Tables Pressure vs Temperature

PS = 16 Bar / 120 °C

S606 PS=20 Bar		S608 PS=16 Bar/110°C	
	Fluid. Gr-1	Fluid. Gr-2	
Art. 4.3	0-2	0-6	Art. 4.3
I	4-6	8-24	I
II	8-24	26-126	II
III	26-126	128-280	III
IV	128-280		IV

PS = 20 Bar / 50 °C

S727 PS=20 Bar	
	Fluid. Gr-2
Art. 4.3	0-8
I	10-56
II	58-276
III	278-300
IV	

PS = 30 Bar / 120 °C

S6 PS=30 Bar		S7 PS=30 Bar		S9 PS=30 Bar		S22 PS=30 Bar	
	Fluid. Gr-1	Fluid. Gr-2		Fluid. Gr-1	Fluid. Gr-2		Fluid. Gr-1
Art. 4.3	0-48	0-96	Art. 4.3	0-44	0-90	Art. 4.3	0-30
I	50-96	98-120	I	46-90	92-120	I	32-62
II	98-120		II	92-120		II	64-120
III			III			III	
IV			IV			IV	

S62 PS=30 Bar		S11-12 PS=30 Bar		S16 PS=30 Bar		S82/87/93 PS=30 Bar	
	Fluid. Gr-1	Fluid. Gr-2		Fluid. Gr-1	Fluid. Gr-2		Fluid. Gr-1
Art. 4.3	0-20	0-42	Art. 4.3	0-22	0-46	Art. 4.3	0-20
I	22-42	44-160	I	24-46	48-120	I	22-40
II	44-160		II	48-120		II	42-120
III			III			III	
IV			IV			IV	

S182 PS=30 Bar		S202 PS=30 Bar		S222 PS=30 Bar		S424 PS=30 Bar	
	Fluid. Gr-1	Fluid. Gr-2		Fluid. Gr-1	Fluid. Gr-2		Fluid. Gr-1
Art. 4.3	0-2	0-4	Art. 4.3	0-6	0-12	Art. 4.3	0-16
I	4-4	6-22	I	8-12	14-48	I	18-26
II	6-22	24-118	II	14-48	50-240	II	28-100
III	24-118	120-280	III	50-240		III	102-240
IV	120-280		IV			IV	

S404 PS=30 Bar		S71 PS=30 Bar		S101 PS=30 Bar	
	Fluid. Gr-1	Fluid. Gr-2		Fluid. Gr-1	Fluid. Gr-2
Art. 4.3	0-2	0-4	Art. 4.3	0-16	0-26
I	4	6-22	I	18-26	28-110
II	6-22	24-118	II	28-110	112-200
III	24-118	120-280	III	112-200	
IV	120-280		IV		

PS = 45 Bar / 120 °C

S6H PS=45 Bar		S7H PS=45 Bar		S22H PS=45 Bar		S101H PS=45 Bar		187 PS=30 Bar	
	Fluid. Gr-1	Fluid. Gr-2		Fluid. Gr-1	Fluid. Gr-2		Fluid. Gr-1	Fluid. Gr-2	
Art. 4.3	0-32	0-64	Art. 4.3	0-30	0-60	Art. 4.3	0-8	0-16	Art. 4.3
I	34-64	66-120	I	32-60	62-120	I	10-16	18-68	I
II	66-120		II	62-120		II	18-68	70-240	II
III			III			III	70-240		III
IV			IV			IV			IV

S62H PS=45 Bar		S82H PS=45 Bar		S16H PS=45 Bar		85 PS=30 Bar	
	Fluid. Gr-1	Fluid. Gr-2		Fluid. Gr-1	Fluid. Gr-2		Fluid. Gr-1
Art. 4.3	0-12	0-26	Art. 4.3	0-16	0-18	Art. 4.3	0-20
I	14-26	28-106	I	18	20-72	I	22-34
II	28-106	108-160	II	20-72	74-240	II	36-136
III	108-160		III	74-240		III	136-200
IV			IV			IV	

PS = 49 Bar / 150 °C

S9H PS=49 Bar		S12H PS=49 Bar		87H/93H PS=49 Bar		S182H PS=49 Bar		85H PS=49 Bar	
	Fluid. Gr-1	Fluid. Gr-2		Fluid. Gr-1	Fluid. Gr-2		Fluid. Gr-1	Fluid. Gr-2	
Art. 4.3	0-36	0-36	Art. 4.3	0-28	0-28	Art. 4.3	0-6	0-6	Art. 4.3
I		38-120	I		30-114	I		8-30	I
II	38-120		II	30-114	116-140	II	8-30	32-150	II
III			III	116-140		III	32-150	152-240	III
IV			IV			IV	152-240		IV

S62H PS=49 Bar		S202H PS=49 Bar		S222H PS=49 Bar		S424H PS=49 Bar		S187H PS=49 Bar	
	Fluid. Gr-1	Fluid. Gr-2		Fluid. Gr-1	Fluid. Gr-2		Fluid. Gr-1	Fluid. Gr-2	
Art. 4.3	0-24	0-24	Art. 4.3	0-6	0-6	Art. 4.3	0-10	0-10	Art. 4.3
I		26-106	I		8-30	I		12-34	I
II	26-106	108-150	II	8-30	32-150	II	12-34	36-168	II
III	108-150		III	32-150	152-240	III	36-168	170-280	III
IV			IV	152-240		IV	170-280		IV

GARANZIA

A - Onda S.p.A. garantisce l'assenza di vizi e difetti nella lavorazione e nei materiali nei Prodotti per 18 mesi dalla data della consegna.

Pertanto ove, durante il periodo di garanzia, i contestati difetti dei Prodotti risultino oggettivamente fondati e siano riconosciuti per iscritto da Onda S.p.A., quest'ultima provvederà gratuitamente alla riparazione o, a sua discrezione, alla sostituzione dei Prodotti difettosi, con consegna effettuata franco fabbrica (Ex Works – Incoterms 2000) Stabilimento di Onda S.p.A. in Via Lord Baden Powell, 11 – 36045 Lonigo (VI).

B - Pena di decadenza dalla garanzia, il Cliente dovrà denunciare per iscritto, a mezzo raccomandata con ricevuta di ritorno, i vizi o i difetti riscontrati entro e non oltre 10 (dieci) giorni dal ricevimento dei Prodotti o evidenziati dalla messa in funzione dell'impianto, oppure, trattandosi di vizi e/o difetti occulti, entro e non oltre 10 (dieci) giorni dalla scoperta degli stessi. In questo caso, l'onere della prova della data della scoperta graverà sul Cliente.

C - Onda S.p.A. garantisce inoltre che i Prodotti sono fabbricati in conformità alle leggi italiane e alle normative comunitarie vigenti alla data di conferma da parte di Onda S.p.A. del relativo ordine del Cliente.

Salvo diverso accordo scritto tra le parti, tutte le altre spese accessorie agli interventi di sostituzione e/o di riparazione, saranno a carico e a rischio del Cliente.

D - La garanzia è esclusa qualora i vizi o difetti dei Prodotti siano stati determinati dalle seguenti cause:

- Naturale usura e deterioramento.
- Riparazioni, manomissioni o modifiche non autorizzate.
- Uso e applicazione impropri.
- Eccessiva sollecitazione termica, anche occasionale.
- Eccessiva sollecitazione elettrica o meccanica.
- Mancato rispetto dei parametri funzionali e ambientali indicati da Onda S.p.A. per il corretto impiego e funzionamento dei Prodotti.
- Installazione dei Prodotti difforme da quella indicate nelle specifiche tecniche fornite da Onda S.p.A.
- Mancata messa a terra dello scambiatore.
- Qualsiasi altra causa imputabile a negligenza del Cliente.

E - La garanzia è inoltre esclusa in caso di:

- Eventuale non conformità dei Prodotti a normative italiane e/o comunitarie entrate in vigore dopo la data della trasmissione della conferma d'ordine di Onda S.p.A.;
- Eventuale non conformità dei Prodotti a leggi e/o normative in vigore nel luogo in cui i Prodotti sono installati e/o assemblati dal Cliente e/o nel luogo di finale utilizzazione dei Prodotti, qualora il Cliente non abbia espressamente richiesto la conformità dei Prodotti a tali leggi e/o normative e non abbia regolarmente informato ONDA S.p.A. del loro contenuto prima della data di trasmissione della conferma d'ordine di quest'ultima. Resta inteso che la presente limitazione si intende efficace anche con riferimento a specifiche normative vigenti in Stati dell'Unione Europea ed applicabili in via autonoma rispetto alle normative comunitarie.

F - Il Cliente non dovrà vendere o commercializzare Prodotti non conformi alle leggi e/o normative indicate nella precedente lettera E. In caso contrario, il Cliente manleverà ONDA S.p.A. da ogni danno e/o perdita dalla stessa sofferto in seguito a contestazioni, sollevate in via giudiziale o stragiudiziale, da qualsiasi soggetto terzo o da pubblica autorità in conseguenza della fabbricazione da parte di ONDA S.p.A. di prodotti non conformi alle summenzionate leggi e/o normative.

G - Ferma restando l'applicazione del DPR 224/1988, in materia di responsabilità per danno da prodotti difettosi, e la responsabilità di Onda S.p.A. in caso di dolo o colpa grave, quest'ultima non sarà in alcun caso responsabile per i danni diretti, indiretti o incidentali che dovessero in qualsiasi modo derivare dalla difettosità dei Prodotti.

WARRANTY

A - Onda S.p.A. warrants that the Products shall be free from defects in material and workmanship for a period of 18 months from the date of the delivery.

Therefore, should Onda S.p.A., within the warranty period, acknowledge and recognise in writing the existence of the defects in the products and said defects be materially grounded, Onda S.p.A. shall, at its discretion, repair the defective Products at no costs for the Client or replace them by delivering the substitutive products Ex works (Incoterms 2000) at Onda S.p.A.'s premises (Via Lord Baden Powell, 11 – 36045 Lonigo (VI) – Italy).

B - Subject to loss of the warranty, notice of any defect shall be given by the Client in writing with return receipt registered letter within, and not later than, 10 (ten) days from the date of receipt of the products or from the start up of the plant. Subject to loss of the warranty, notice of any latent defect of the Products by the Client shall be given in writing, by return receipt registered letter, within and not later than 10 (ten) days from the date of the relevant discovery. It is hereby understood that the burden of the proof of the date of the discovery shall be borne by the Client.

C - Onda S.p.A. also warrants that the Products are manufactured in compliance with the Italian and European Laws and Regulations in force on the date of the confirmation by Onda S.p.A. of the relevant Client's order. Unless otherwise expressly agreed in writings by the parties, Client shall bear any other additional expenses related to the operations of repairing or replacing of the defective products.

D - This warranty shall not apply should the defects of the Products be caused by:

- Natural wear and tear.
- Unauthorised repairs, interventions or modifications.
- Unsuitable use or application.
- Thermal overexposure, also when occasional.
- Electrical or mechanical over-stress.
- Failure of respecting the functional and environmental parameters suggested by Onda S.p.A. for the correct use and exploitation of the products.
- Installation of the products not in compliance with the technical specifications provided by Onda S.p.A.
- Missing earth grounding.
- Any other cause due to the Client's negligence.

E - This warranty shall also not apply in case of:

- Non compliance of the Products with Italian and European Laws and/or Regulations entered in force after the date of transmission of the order confirmation by Onda S.p.A.
- Non compliance of the Products with Laws and/or Regulations in force in the place where the Products are installed and/or assembled by the Client and/or in the place of their final use, should the Client not expressly require the conformity of the Products to said Laws and Regulations and not duly inform Onda S.p.A. of their content before the date of transmission of the latter's order confirmation. This limitation of the warranty is also applicable with reference to peculiar Laws and Regulations valid and binding in States of the European Union independently of the European Laws and Regulations.

F - The Client shall not sell or market Products not in compliance with the Laws and Regulations mentioned under letter E above. In the negative, the Client shall keep ONDA S.p.A. harmless of any damage or loss suffered by the latter, due to any third party's and/or authority's claim raised as a consequence of the manufacture by ONDA S.p.A. of Products not in compliance with the above mentioned Laws and Regulations.

G - Without prejudice to the application of DPR 224/1988 on product liability and liability for gross negligence or wilful misconduct, Onda S.p.A. shall never be liable for direct, indirect or occasional damages which in any manner derived from defective products.



ONDA S.p.A.

onda@onda-it.com
www.onda-it.com

PLANT 1 Headquarters

Via Dante Alighieri, 27B
 36065 Mussolente (VI)
 Italy
 t. +39 0424 87633

PLANT 2

Via L. Baden Powell, 11
 36045 Lonigo (VI)
 Italy
 t. +39 0444 720720

PLANT 3

Via Vittoria, 158A
 36065 Mussolente (VI)
 Italy
 t. +39 0424 87506

PLANT 4

Onda USA L.L.C.
 600 London Rd
 Delaware, OH 43015
 t. +1 614 321 3342
www.onda-us.com
onda@onda-us.com

PLANT 5

Onda Nordic OY
 Lentolantie 22 - 36220
 Kangasala Tampere, Finland
 t. +35 8331437300
 m. +35 8409012999
www.ondanordic.com
pasi.makinen@ondanordic.com

Onda France S.A.R.L.

320, Avenue Berthelot
 69008 Lyon France
 t. +33 472784606
 m. +33 608341000
www.onda-fr.com
abouzat@onda-fr.com

Onda RU

Mayakovskogo Street, 18a, Khimki,
 Moscow Region, Russia 141402
 t. +7 916 676 16 54
 m. +7 495 971 88 53
www.onda-it.com
info@onda-ru.com

Onda Shanghai

Heat Exchanger Co., Ltd.
 瓯蒨啞 (上海) 热交换有限公司
 Shanghai, Changning District,
 Anhua Road 492, Building 1 Tower A, Room 126
 上海市长宁区安化路492号1幢 (A座) 126室A092
 t. +86 021 6056 4838 (ext.1000)
 m. +33 6 08 34 10 00